

# 40 Gbps Ethernet Single Mode Transceiver

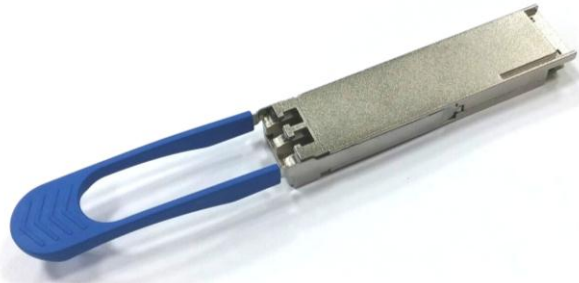

QSFP+, Duplex LC Connector, 4xCWDM LD for Single Mode Fiber, RoHS Compliant

Digital Diagnostics Functions

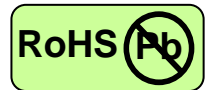

## Features

- 4x10Gbps uncooled CWDM O-band LD
- Data Rate: 41.2Gbps, NRZ
- RoHS Compliant and Lead-free
- Compliant to QSFP+ MSA SFF-8436
- Compliant with specifications for IEEE-802.3ba 40GBASE-LR4 at 41.2 Gbps
- Digital Diagnostic Monitoring Interface
- Duplex LC Connector
- Transmission distance up to 10km
- Low power consumption < 3.5W
- Compliant with Laser Class 1 IEC / CDRH

## Applications

- 40Gigabit Ethernet Links

## Description

The CT-D000TQP-CB4L-D from Coretek Opto Corp. is a high performance, optimum heat dissipation and excellent electromagnetic shielding module for serial optical data communication applications specified for single mode of data rate 41.2 Gb/s. The module is intended for single mode fiber, operates at a nominal wavelength of CWDM and complies with Multi-Source Agreement (MSA) QSFP+. Each module is integrated digital diagnostics functions via an I<sup>2</sup>C serial interface.

The module is a duplex LC connector transceiver designed to provide 40 Gigabit Ethernet compliant link at 41.2 Gb/s intermediate reach applications. The characteristics are performed in accordance with IEEE802.3ba.

## EMC

Most equipment utilizing high-speed transceivers will be required to meet the following requirements:

- 1) FCC in the United States
- 2) CENELEC EN55022 (CISPR 22) in Europe

To assist the customer in managing the overall equipment EMC performance, the transceivers have been designed to satisfy FCC class B limits and provide good immunity to radio-frequency electromagnetic fields.

## Eye Safety

This laser based single mode transceiver is a Class 1 product. It complies with IEC 60825-1 Ed.2: 2007 and FDA performance standards for laser products (21 CFR 1040.10 and 1040.11) except for deviations pursuant to Laser Notice 50, dated June 24, 2007.

### CLASS 1 LASER PRODUCT

#### DO NOT VIEW DIRECTLY WITH OPTICAL INSTRUMENTS

Caution: use of controls or adjustments or performance of procedures other than those specified herein may result in hazardous radiation.

*Note: All adjustments have been made at the factory prior to shipment of the devices. No maintenance or alteration to the device is required. Tampering with or modifying the performance of the device will result in voided product warranty. Failure to adhere to the above restrictions could result in a modification that is considered an act of "manufacturing", and will require, under law, recertification of the modified product with the U.S. Food and Drug Administration (ref. 21 CFR 1040.10 (i)).*

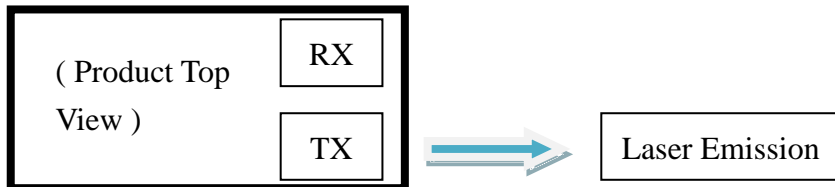

Wavelength	> 1310 nm
Maximum total output power (as defined by IEC: 7 mm aperture at 70 mm distance)	< 15.6 mW / 11.9 dBm
Beam divergence (full angle) / NA (half angle)	11° / 0.1 rad

# 40 Gbps Ethernet Single Mode Transceiver



## Product Information

Model Number	Wavelength	Output Power/Lane	Sensitivity/Lane	Distance
CT-D000TQP-CB4L-D	CWDM O-band	-7 ~ +2.3 dBm	$\leq -13.7$ dBm	10km

## ABSOLUTE MAX RATINGS

PARAMETER	SYMBOL	MIN	MAX	UNIT	NOTE
Storage Temperature	T <sub>s</sub>	-40	85	°C	
Supply Voltage	V <sub>CC</sub>	-0.5	3.6	V	
Relative Humidity	RH	5	85	%	

## OPERATING CONDITIONS

PARAMETER	SYMBOL	MIN.	TYP.	MAX.	UNIT	NOTE
Case Operating Temperature	T <sub>C</sub>	0		70	°C	
Supply Voltage	V <sub>CC</sub>	3.14	3.30	3.47	V	
Supply Current	I <sub>CC</sub>			1000	mA	
Aggregate Data Rate				41.2	Gb/s	
Data Rate per Lane				10.3125	Gb/s	

## ELECTRICAL CHARACTERISTICS

PARAMETER	SYMBOL	MIN	MAX	UNIT	NOTE
<b>Transmitter (per Lane)</b>					
Data Input Differential Voltage	V <sub>ID</sub>	120	1200	mV	
Single Ended Input Voltage	V <sub>IS</sub>	-0.3	4	V	
Differential Input Return Loss		Compliant with IEEE 802.3ba		dB	
<b>Receiver (per Lane)</b>					
Data Output Differential Voltage	V <sub>OD</sub>	0	800	mV	2
Single Ended Output Voltage	V <sub>OS</sub>	-0.3	4	V	
Differential Output Return Loss		Compliant with IEEE 802.3ba		dB	
Common Mode Output Return Loss		Compliant with IEEE 802.3ba		dB	
SDA, SCL - Low	V <sub>IL</sub>	-0.3	V <sub>CC</sub> × 0.3	V	
SDA, SCL - High	V <sub>IH</sub>	V <sub>CC</sub> × 0.7	V <sub>CC</sub> + 0.5	V	

## TRANSMITTER ELECTRO-OPTICAL CHARACTERISTICS

PARAMETER	SYMBOL	MIN	TYP.	MAX	UNIT	NOTE
Total Optical Launch Power (average)	P <sub>to</sub>			8.3	dBm	
Optical Launch Power per Lane (average)	P <sub>o</sub>	-7		2.3	dBm	
Optical Modulation Amplitude per Lane	OMA	-4		3.5	dBm	
Difference in optical power between any two lanes (OMA)	DP			6.5	dB	
Extinction Ratio	ER	3.5			dB	
Lane Center Wavelength	$\lambda_c$	1264.5		1277.5	nm	
		1284.5		1297.5		
		1304.5		1317.5		
		1324.5		1337.5		
Side Mode Suppression Ratio	SMSR	30			dB	
Transmitter OFF Power per Lane	P <sub>off</sub>			-30	dBm	
Transmitter Dispersion Penalty per Lane	TDP			2.6	dB	
Transmitter Reflectance	RL			-12	dB	

# 40 Gbps Ethernet Single Mode Transceiver



Optical Return Loss Tolerance		20	dB
Relative Intensity Noise(OMA)	RIN	-128	dB/Hz
Eye Mask	Compliant with IEEE 802.3ba		

## RECEIVER ELECTRO-OPTICAL CHARACTERISTICS

PARAMETER	SYMBOL	MIN	TYP.	MAX	UNIT	NOTE
Input Optical Power per Lane (average)	$P_{in}$			1.1	dBm	1
Receiver Sensitivity per Lane (OMA)	$P_{min}$			-11.5	dBm	1
Stressed Receiver Sensitivity per Lane(OMA)	$P_{min}$			-9.6	dBm	1
Damage Threshold per Lane				3.3	dBm	
LOS of Signal - Deasserted	$P_D$			-15	dBm	
LOS of Signal - Asserted	$P_A$	-28			dBm	
LOS of Signal - Hysteresis	Hys		1		dB	
Receiver Reflectance	RL			-26	dB	
Lane Operating Wavelength	$\lambda$	1264.5		1277.5	nm	
		1284.5		1297.5		
		1304.5		1317.5		
		1324.5		1337.5		

### Notes:

1. Measured with  $2^{31}-1$  PRBS at BER< $10^{-12}$

## BLOCK DIAGRAM OF TRANSCEIVER

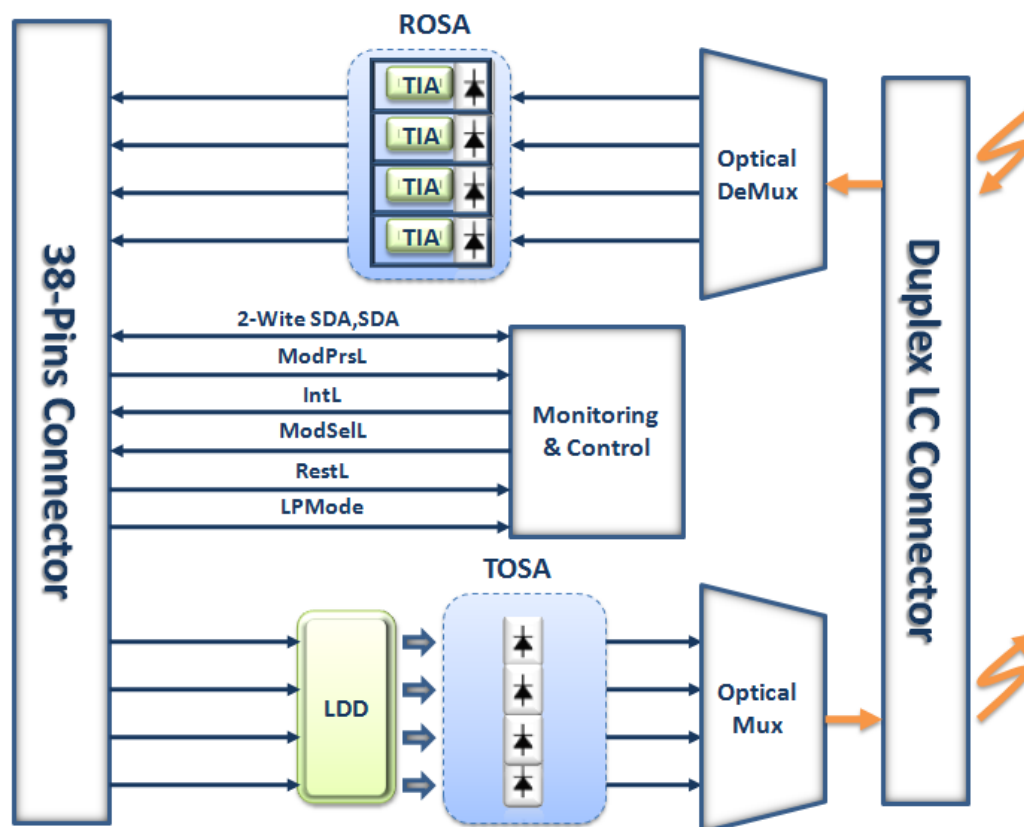

# 40 Gbps Ethernet Single Mode Transceiver



## PIN OUT DIAGRAM OF TRANSCEIVER

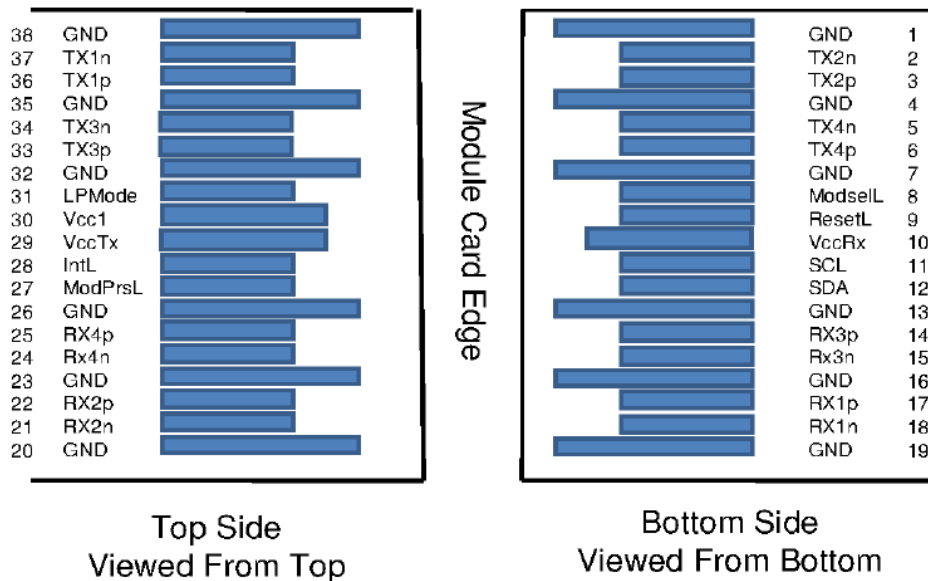

## PIN OUT TABLE

Pin	Symbol	Logic	Functional Description	Note
1	GND		Ground	1
2	TX2n	CML-I	Transmitter Inverted Data Input	
3	TX2p	CML-I	Transmitter Non-inverted Data Input	
4	GND		Ground	1
5	TX4n	CML-I	Transmitter Inverted Data Input	
6	TX4p	CML-I	Transmitter Non-inverted Data Input	
7	GND		Ground	1
8	ModselL	LVTTL-I	Module Select	
9	ResetL	LVTTL-I	Module Reset	
10	Vcc Rx		+3.3V Power Supply Receiver	
11	SCL	LVC MOS-I/O	2-wire Serial Interface Clock	
12	SDA	LVC MOS-I/O	2-wire Serial Interface Data	
13	GND		Ground	1
14	RX3p	CML-O	Receiver Non-inverted Data Output	
15	RX3n	CML-O	Receiver Inverted Data Output	
16	GND		Ground	1
17	RX1p	CML-O	Receiver Non-inverted Data Output	
18	RX1n	CML-O	Receiver Inverted Data Output	
19	GND		Ground	1
20	GND		Ground	1
21	RX2n	CML-O	Receiver Inverted Data Output	
22	RX2p	CML-O	Receiver Non-inverted Data Output	
23	GND		Ground	1
24	RX4n	CML-O	Receiver Inverted Data Output	
25	RX4p	CML-O	Receiver Non-inverted Data Output	
26	GND		Ground	1

# 40 Gbps Ethernet Single Mode Transceiver



27	ModPrsL	LVTTL-O	Module Present	
28	IntL	LVTTL-O	Interrupt	
29	Vcc Tx		+3.3V Power Supply Transmitter	
30	Vcc1		+3.3V Power Supply	
31	LPMODE	LVTTL-I	Low Power Mode	
32	GND		Ground	1
33	TX3p	CML-I	Transmitter Non-inverted Data Input	
34	TX3n	CML-I	Transmitter Inverted Data Input	
35	GND		Ground	
36	TX1p	CML-I	Transmitter Non-inverted Data Input	
37	TX1n	CML-I	Transmitter Inverted Data Input	
38	GND		Ground	1

**Notes:**

1. Module ground pins GND are isolated from the module case and chassis ground within the module.

## RECOMMENDED CIRCUIT SCHEMATIC

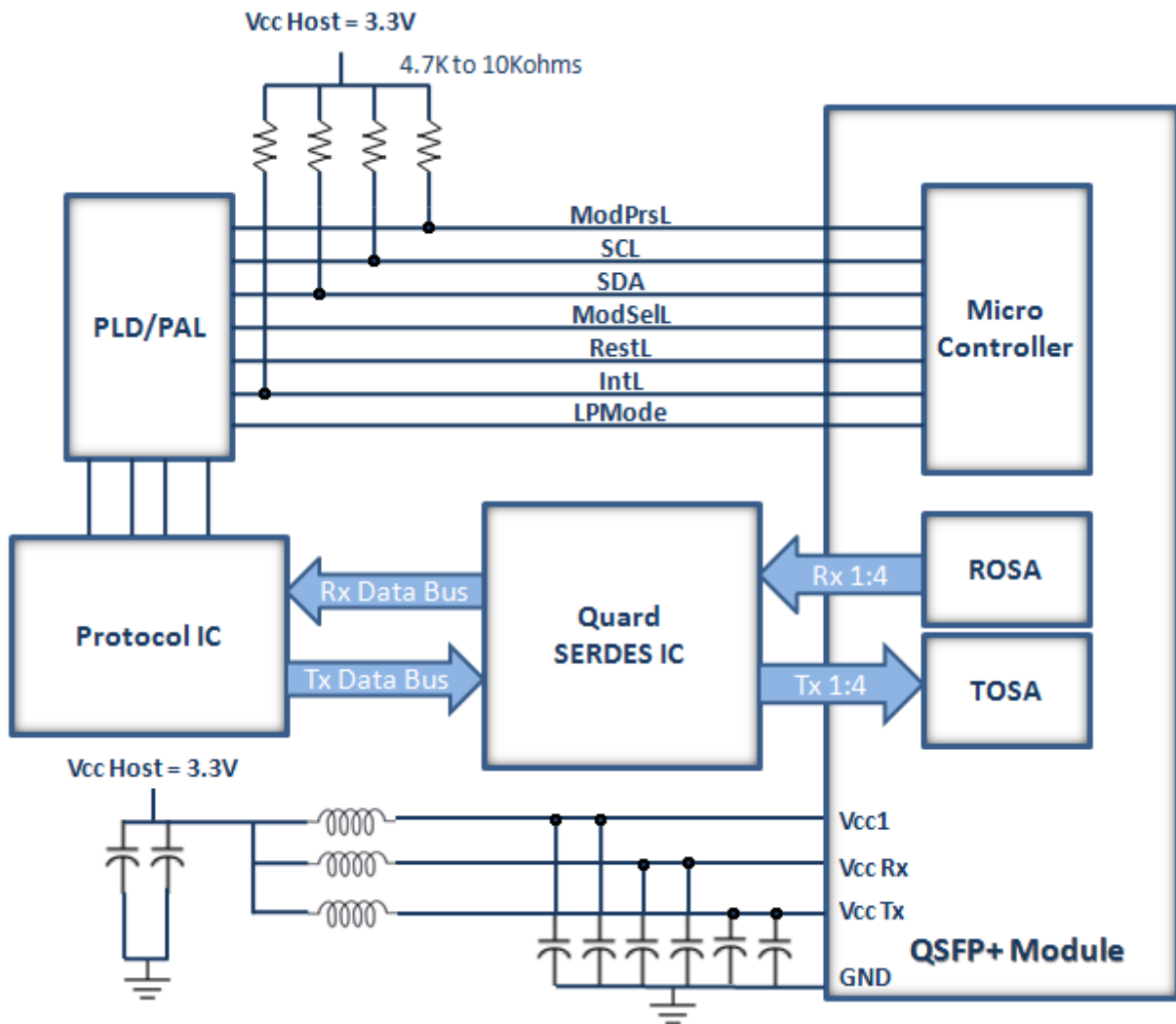

## MECHANICAL DIMENSIONS

Units in mm

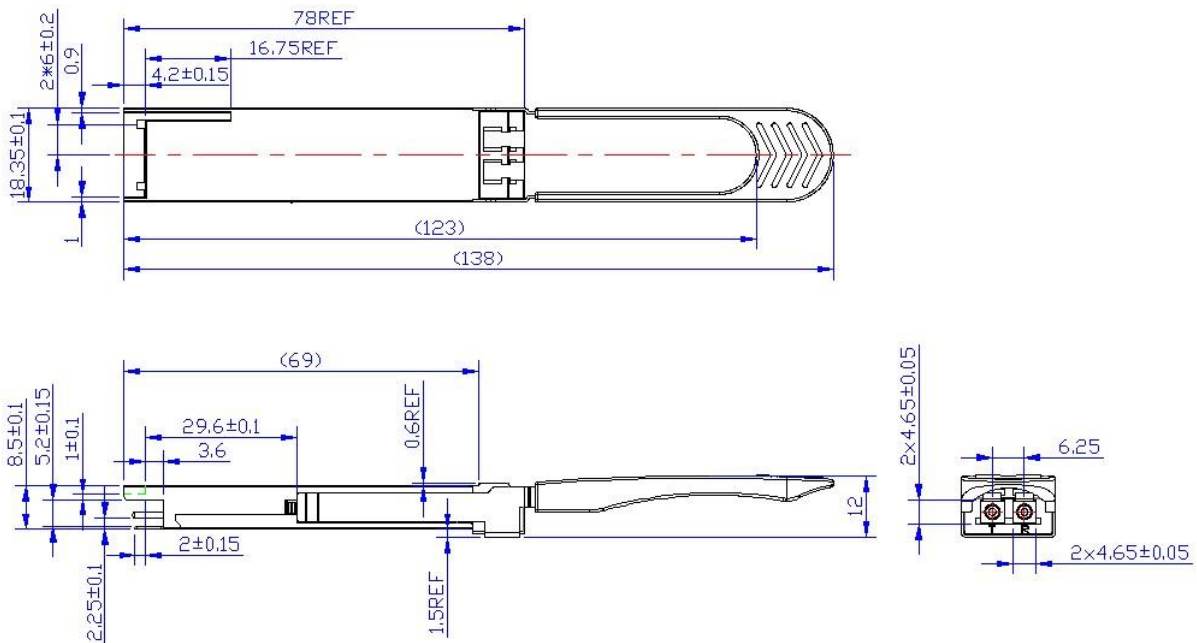

All dimensions are  $\pm 0.2$ mm unless otherwise specified.

### Claim:

CORETEK Opto Corp. reserves the right to make changes in the specification described hereinafter without prior notice.