

10 Gb/s Single Mode Transceiver

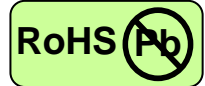

SFP+, Duplex LC Connector, 1550 nm EML LD for Single Mode Fiber, RoHS Compliant

Digital Diagnostics Functions, Operating Case Temperature from 0 to +70 °C



Features

- 1550 nm EML TOSA
- Data Rate: 9.95 Gb/s to 11.3 Gb/s, NRZ
- RoHS Compliant and Lead-free
- Compliant to SFP+ Electrical MSA SFF-8431
- Compliant to SFP+ Mechanical MSA SFF-8432
- Compliant with specifications for IEEE-802.3ae 10GBASE-ER at 10.3125 Gb/s
- Digital Diagnostic Monitoring Interface
- Duplex LC Connector
- Transmission distance up to 40 km
- Compliance with ESD contact discharge EN 61000-4-2 level 4
- Compliant with Laser Class 1 IEC / CDRH

Applications

- 10Gigabit Ethernet Links
- High-speed Storage Area Networks

Preliminary

Description

The CT-A000TPP-KB6L-D from Coretek Opto Corp. is a high performance module, with optimum heat dissipation and excellent electromagnetic shielding, for serial optical data communication applications specified for a data rate 10.3125 Gb/s. The module is intended for single mode fiber, operates at a nominal wavelength of 1550 nm and complies with Multi-Source Agreement (MSA) SFP+. Each module is integrated with digital diagnostics functions via an I²C serial interface.

The module is a duplex LC connector transceiver designed to provide 10 Gigabit Ethernet compliant links at 10.3 Gb/s and 10.5 Gb/s intermediate reach applications. The characteristics are performed in accordance with IEEE802.3ae Physical Interface.

EMC

Most equipment utilizing high-speed transceivers will be required to meet the following requirements:

- 1) FCC in the United States
- 2) CENELEC EN55022 (CISPR 22) in Europe

To assist the customer in managing the overall equipment EMC performance, the transceivers have been designed to satisfy FCC class B limits and provide good immunity to radio-frequency electromagnetic fields.

Eye Safety

This laser based single mode transceiver is a Class 1 product. It complies with IEC 60825-1 Ed.2: 2007 and FDA performance standards for laser products (21 CFR 1040.10 and 1040.11) except for deviations pursuant to Laser Notice 50, dated June 24, 2007.

CLASS 1 LASER PRODUCT

DO NOT VIEW DIRECTLY WITH OPTICAL INSTRUMENTS

Caution: use of controls or adjustments or performance of procedures other than those specified herein may result in hazardous radiation.

Note: All adjustments have been made at the factory prior to shipment of the devices. No maintenance or alteration to the device is required. Tampering with or modifying the performance of the device will result in voided product warranty. Failure to adhere to the above restrictions could result in a modification that is considered an act of "manufacturing", and will require, under law, recertification of the modified product with the U.S. Food and Drug Administration (ref. 21 CFR 1040.10 (i)).

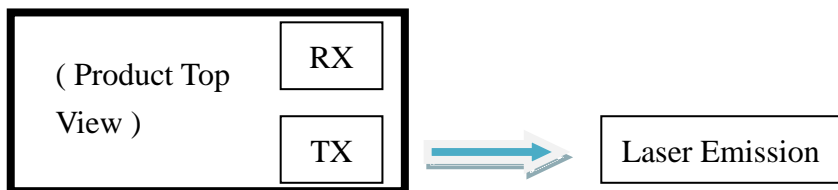

Wavelength $> 1310 \text{ nm}$
Maximum total output power $< 15.6 \text{ mW} / 11.9 \text{ dBm}$
(as defined by IEC: 7 mm aperture at 70 mm distance)
Beam divergence (full angle) / NA (half angle) $11^\circ / 0.1 \text{ rad}$

10 Gb/s Single Mode Transceiver



Product Information

Model Number	Wavelength	Output Power	Sensitivity	Distance
CT-A000TPP-KB6L-D	1550 nm	-4.7 ~ +4 dBm	≤ -14.1 dBm	40 km

ABSOLUTE MAX RATINGS

PARAMETER	SYMBOL	MIN	MAX	UNIT	NOTE
Storage Temperature	T _s	-40	85	°C	
Supply Voltage	V _{CC}	-0.5	3.6	V	
Relative Humidity	RH	0	85	%	

OPERATING CONDITIONS

PARAMETER	SYMBOL	MIN.	TYP.	MAX.	UNIT	NOTE
Case Operating Temperature	T _C	0		70	°C	
Supply Voltage	V _{CC}	3.14	3.30	3.47	V	
Supply Current	I _{CC}		360	500	mA	
Data Rate		9.95	10.3125	11.3	Gb/s	

ELECTRICAL CHARACTERISTICS

PARAMETER	SYMBOL	MIN	MAX	UNIT	NOTE
Transmitter					
Data Input Differential Voltage	V _{ID}	180	700	mV	
Tx_Disable Input Voltage - Low	V _{IL}	-0.3	0.8	V	
Tx_Disable Input Voltage - High	V _{IH}	2.0	V _{CC} + 0.3	V	
Tx_Fault Output Voltage - Low	V _{OL}	-0.3	0.4	V	
Tx_Fault Output Current - High	I _{OH}	-50	37.5	μA	1
Receiver					
Data Output Differential Voltage	V _{OD}	300	850	mV	2
Rx_LOS Output Voltage - Low	V _{OL}	-0.3	0.4	V	
Rx_LOS Output Current - High	I _{OH}	-50	37.5	μA	1
SDA, SCL - Low	V _{IL}	-0.3	V _{CC} × 0.3	V	
SDA, SCL - High	V _{IH}	V _{CC} × 0.7	V _{CC} + 0.5	V	

TRANSMITTER ELECTRO-OPTICAL CHARACTERISTICS

PARAMETER	SYMBOL	MIN	TYP	MAX	UNIT	NOTE
Optical Output Power (average)	P _o	-4.7		+4	dBm	
Center Wavelength	λ _c	1530		1565	nm	
Spectral Width (-20dB)	Δλ			1	nm	
Side Mode Suppression Ratio	SMSR	30			dB	
Transmitter OFF Power	P _{off}			-30	dBm	
Transmitter Dispersion Penalty	TDP			3.2	dB	
Extinction Ratio	ER	3			dB	
Relative Intensity Noise(OMA)	RIN			-128	dB/Hz	

* The laser shutdown is deactivated.

10 Gb/s Single Mode Transceiver



RECEIVER ELECTRO-OPTICAL CHARACTERISTICS

PARAMETER	SYMBOL	MIN	TYP.	MAX	UNIT	NOTE
Maximum Input Optical Power	P_{max}	0.5			dBm	
Receiver Sensitivity (OMA)	P_{min}			-14.1	dBm	3
LOS of Signal - Deasserted	P_D			-15	dBm	
LOS of Signal - Asserted	P_A	-30			dBm	
LOS of Signal - Hysteresis	Hys	0.5			dB	
Reflectance	RL			-26	dB	
Operating Wavelength	λ	1260		1600	nm	

Notes:

1. Measured with a 4.7k Ω load pulled up to Vcc_Host
2. Into 100 Ω differential termination
3. Measured with $2^{31}-1$ PRBS at BER< 10^{-12}

TIMING CHARACTERISTICS

PARAMETER	SYMBOL	MIN	TYP.	MAX	UNIT	NOTE
TX_DISABLE Assert Time	t_{off}			10	μ s	
TX_DISABLE Negate Time	t_{on}			2	ms	
Time to initialize, include reset of TX_FAULT	t_{init}			300	ms	
TX_FAULT from fault to assertion	t_{fault}			100	μ s	
TX_DISABLE time to start reset	t_{reset}	10			μ s	
Receiver Loss of Signal Assert Time (off to on)	t_{A,RX_LOS}			100	μ s	
Receiver Loss of Signal Assert Time (on to off)	t_{D,RX_LOS}			100	μ s	

DIGITAL DIAGNOSTIC MONITOR ACCURACY

PARAMETER	SYMBOL	MIN	MAX	UNIT	NOTE
Transceiver Temperature	T	-3	+3	$^{\circ}$ C	
Power Supply Voltage	V	-3	+3	%	
TX Bias Current	T_x_I	-10	+10	%	
TX Optical Power	T_x_PWR	-2	+2	dB	
RX Optical Power	R_x_PWR	-3	+3	dB	

BLOCK DIAGRAM OF TRANSCEIVER

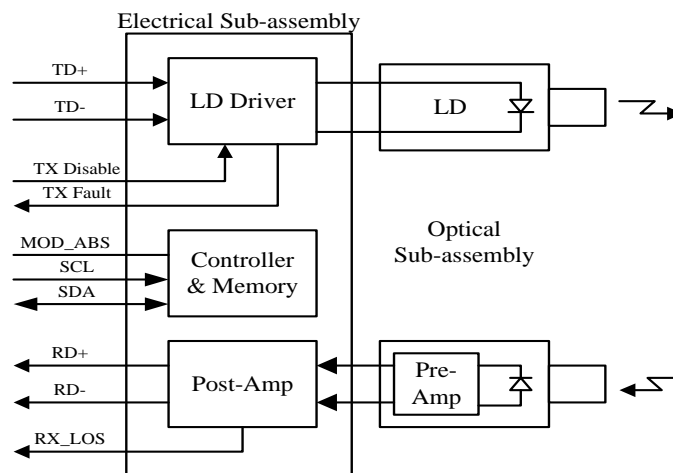

10 Gb/s Single Mode Transceiver



PIN OUT DIAGRAM OF TRANSCEIVER

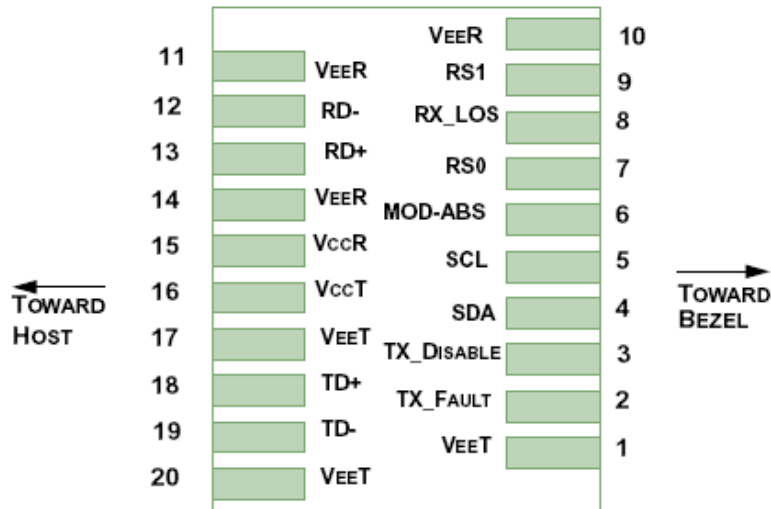

PIN OUT TABLE

Pin	Symbol	Logic	Functional Description	Note
1	V _{EE} T		Transmitter Ground	1
2	TX_FAULT	LVTTL-O	Transmitter Fault Indication	2
3	TX_DISABLE	LVTTL-I	Transmitter Disable - Module disables on high or open	3
4	SDA	LVTTL-I/O	Two wire serial ID interface data line	4
5	SCL	LVTTL-I/O	Two wire serial ID interface clock	4
6	MOD-ABS		Module absent, connect to V _{ee} T or V _{ee} R in the module	5
7	RS0		No connection required	
8	RX_LOS	LVTTL-O	Loss of Signal	2
9	RS1		No connection required	
10	V _{EE} R		Receiver Ground	1
11	V _{EE} R		Receiver Ground	1
12	RD-	CML-O	Inverse Received Data Out	
13	RD+	CML-O	Received Data Out	
14	V _{EE} R		Receiver Ground	1
15	V _{CC} R		Receiver Power	
16	V _{CC} T		Transmitter Power	
17	V _{EE} T		Transmitter Ground	1
18	TD+	CML-I	Transmitter Data In	
19	TD-	CML-I	Inverse Transmitter Data In	
20	V _{EE} T		Transmitter Ground	1

Notes:

1. Module ground pins GND are isolated from the module case and chassis ground within the module.
2. This is an open collector/drain output that on the host board requires a 4.7-10k Ω pull-up resistor to V_{cc}_Host.
3. This is an input contact with a 4.7-10k Ω pull-up to V_{cc} inside the module.
4. Two-wire serial interface clock and data lines require an external pull-up resistor dependant on the capacitance load.
5. This is a ground return that on the host board requires a 4.7-10k Ω pull-up resistor to V_{cc}_Host.

10 Gb/s Single Mode Transceiver



RECOMMENDED CIRCUIT SCHEMATIC

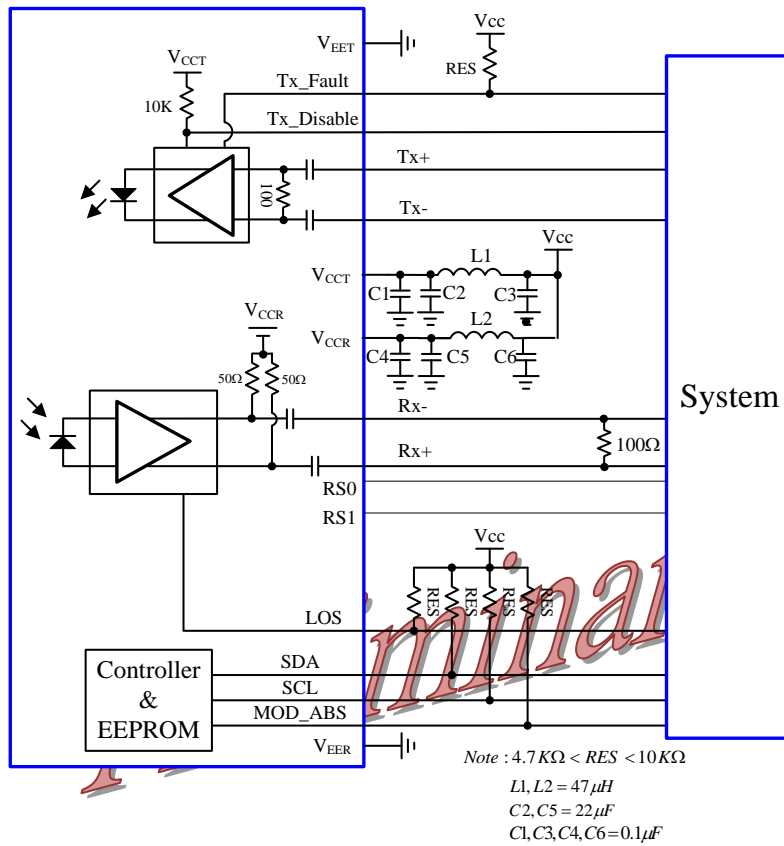

MECHANICAL DIMENSIONS

Units in mm

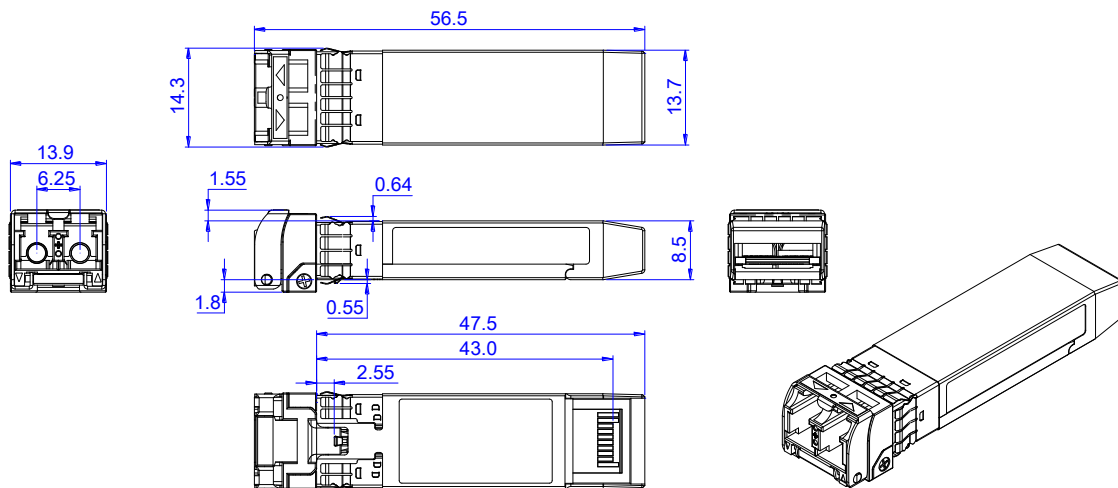

All dimensions are $\pm 0.2\text{mm}$ unless otherwise specified.

Claim:

CORETEK Opto Corp. reserves the right to make changes in the specification described hereinafter without prior notice.