

# 10 Gb/s Single Mode Transceiver



## SFP+, Duplex LC Connector, DWDM EML LD for Single Mode Fiber, RoHS Compliant

Digital Diagnostics Functions, Extended Operating Temperature from  $-40$  to  $+85$  °C, Power Budget 14dB

Preliminary Datasheet

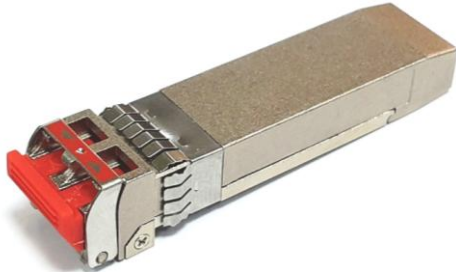

### Features

- C-band 100GHz DWDM 50 channels EML TOSA
- Data Rate: 9.8Gb/s to 10.7 Gb/s, NRZ
- RoHS Compliant and Lead-free
- Compliant to SFP+ Electrical MSA SFF-8431
- Compliant to SFP+ Mechanical MSA SFF-8432
- Compliant with specifications for IEEE-802.3ae 10GBASE-ER at 10.3125 Gb/s
- Digital Diagnostic Monitoring Interface
- Duplex LC Connector
- Compliance with ESD contact discharge EN 61000-4-2 level 4
- Compliant with Laser Class 1 IEC / CDRH

### Applications

- 10Gigabit Ethernet Links
- High-speed Storage Area Networks
- DWDM

### Description

The CT-A000TPP-DB6L-E series from Coretek Opto Corp. are the high performance modules, with optimum heat dissipation and excellent electromagnetic shielding, for serial optical data communication applications specified for a data rate 10.3125 Gb/s. The module is intended for single mode fiber, operates at a nominal wavelength of C-band DWDM and complies with Multi-Source Agreement (MSA) SFP+. Each module is integrated with digital diagnostics functions via an I<sup>2</sup>C serial interface.

The module is a duplex LC connector transceiver designed to provide 10 Gigabit Ethernet compliant links at 10.3 Gb/s and 10.5 Gb/s intermediate reach applications. The characteristics are performed in accordance with IEEE802.3ae Physical Interface.

### EMC

Most equipment utilizing high-speed transceivers will be required to meet the following requirements:

- 1) FCC in the United States
- 2) CENELEC EN55022 (CISPR 22) in Europe

To assist the customer in managing the overall equipment EMC performance, the transceivers have been designed to satisfy FCC class B limits and provide good immunity to radio-frequency electromagnetic fields.

## Eye Safety

This laser based single mode transceiver is a Class 1 product. It complies with IEC 60825-1 Ed.2: 2007 and FDA performance standards for laser products (21 CFR 1040.10 and 1040.11) except for deviations pursuant to Laser Notice 50, dated June 24, 2007.

### CLASS 1 LASER PRODUCT

### DO NOT VIEW DIRECTLY WITH OPTICAL INSTRUMENTS

Caution: use of controls or adjustments or performance of procedures other than those specified herein may result in hazardous radiation.

*Note: All adjustments have been made at the factory prior to shipment of the devices. No maintenance or alteration to the device is required. Tampering with or modifying the performance of the device will result in voided product warranty. Failure to adhere to the above restrictions could result in a modification that is considered an act of “manufacturing”, and will require, under law, recertification of the modified product with the U.S. Food and Drug Administration (ref. 21 CFR 1040.10 (i)).*

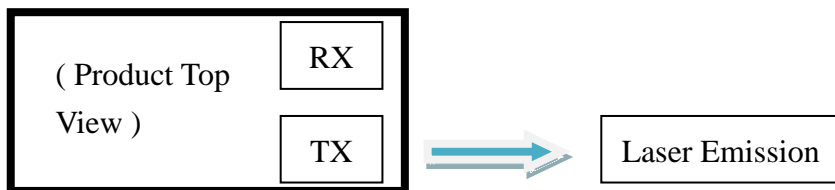

Wavelength : 1550 nm  
Maximum total output power : 10.1 mW / 10 dBm  
(as defined by IEC: 3.5 mm aperture at 14 mm distance)  
Beam divergence (full angle) / NA (half angle) 20° / 0.18 rad

# 10 Gb/s Single Mode Transceiver



## Product Information

Model Number	Wavelength	Output Power	Sensitivity	Power Budget
CT-A000TPP-DB6L-E.xx	DWDM	-2 ~ +2 dBm	$\leq -16$ dBm	14 dB

## Channel Information

Channel	Frequency (THz)	Wavelength	Model Number
13	191.3	1567.133	CT-A000TPP-DB6L-E 13
14	191.4	1566.314	CT-A000TPP-DB6L-E 14
15	191.5	1565.496	CT-A000TPP-DB6L-E 15
16	191.6	1564.679	CT-A000TPP-DB6L-E 16
17	191.7	1563.863	CT-A000TPP-DB6L-E 17
18	191.8	1563.047	CT-A000TPP-DB6L-E 18
19	191.9	1562.233	CT-A000TPP-DB6L-E 19
20	192.0	1561.419	CT-A000TPP-DB6L-E 20
21	192.1	1560.606	CT-A000TPP-DB6L-E 21
22	192.2	1559.794	CT-A000TPP-DB6L-E 22
23	192.3	1558.983	CT-A000TPP-DB6L-E 23
24	192.4	1558.173	CT-A000TPP-DB6L-E 24
25	192.5	1557.363	CT-A000TPP-DB6L-E 25
26	192.6	1556.555	CT-A000TPP-DB6L-E 26
27	192.7	1555.747	CT-A000TPP-DB6L-E 27
28	192.8	1554.940	CT-A000TPP-DB6L-E 28
29	192.9	1554.134	CT-A000TPP-DB6L-E 29
30	193.0	1553.329	CT-A000TPP-DB6L-E 30
31	193.1	1552.524	CT-A000TPP-DB6L-E 31
32	193.2	1551.721	CT-A000TPP-DB6L-E 32
33	193.3	1550.918	CT-A000TPP-DB6L-E 33
34	193.4	1550.116	CT-A000TPP-DB6L-E 34
35	193.5	1549.315	CT-A000TPP-DB6L-E 35
36	193.6	1548.515	CT-A000TPP-DB6L-E 36
37	193.7	1547.715	CT-A000TPP-DB6L-E 37
38	193.8	1546.917	CT-A000TPP-DB6L-E 38
39	193.9	1546.119	CT-A000TPP-DB6L-E 39
40	194.0	1545.322	CT-A000TPP-DB6L-E 40
41	194.1	1544.526	CT-A000TPP-DB6L-E 41
42	194.2	1543.730	CT-A000TPP-DB6L-E 42
43	194.3	1542.936	CT-A000TPP-DB6L-E 43
44	194.4	1542.142	CT-A000TPP-DB6L-E 44
45	194.5	1541.349	CT-A000TPP-DB6L-E 45
46	194.6	1540.557	CT-A000TPP-DB6L-E 46
47	194.7	1539.766	CT-A000TPP-DB6L-E 47
48	194.8	1538.976	CT-A000TPP-DB6L-E 48
49	194.9	1538.186	CT-A000TPP-DB6L-E 49
50	195.0	1537.397	CT-A000TPP-DB6L-E 50
51	195.1	1536.609	CT-A000TPP-DB6L-E 51
52	195.2	1535.822	CT-A000TPP-DB6L-E 52
53	195.3	1535.036	CT-A000TPP-DB6L-E 53
54	195.4	1534.250	CT-A000TPP-DB6L-E 54
55	195.5	1533.465	CT-A000TPP-DB6L-E 55
56	195.6	1532.681	CT-A000TPP-DB6L-E 56
57	195.7	1531.898	CT-A000TPP-DB6L-E 57
58	195.8	1531.116	CT-A000TPP-DB6L-E 58
59	195.9	1530.334	CT-A000TPP-DB6L-E 59
60	196.0	1529.553	CT-A000TPP-DB6L-E 60
61	196.1	1528.773	CT-A000TPP-DB6L-E 61
62	196.2	1527.994	CT-A000TPP-DB6L-E 62

# 10 Gb/s Single Mode Transceiver



## ABSOLUTE MAX RATINGS

PARAMETER	SYMBOL	MIN	MAX	UNIT	NOTE
Storage Temperature	T <sub>S</sub>	-40	85	°C	
Supply Voltage	V <sub>CC</sub>	-0.5	3.6	V	
Relative Humidity	RH	0	85	%	

## OPERATING CONDITIONS

PARAMETER	SYMBOL	MIN.	TYP.	MAX.	UNIT	NOTE
Case Operating Temperature	T <sub>C</sub>	-40		85	°C	
Supply Voltage	V <sub>CC</sub>	3.14	3.30	3.47	V	
Supply Current	I <sub>CC</sub>		400	550	mA	
Data Rate		9.8	10.3125	10.7	Gb/s	

## ELECTRICAL CHARACTERISTICS

PARAMETER	SYMBOL	MIN	MAX	UNIT	NOTE
<b>Transmitter</b>					
Data Input Differential Voltage	V <sub>ID</sub>	180	700	mV	
Tx_Disable Input Voltage - Low	V <sub>IL</sub>	-0.3	0.8	V	
Tx_Disable Input Voltage - High	V <sub>IH</sub>	2.0	V <sub>CC</sub> + 0.3	V	
Tx_Fault Output Voltage - Low	V <sub>OL</sub>	-0.3	0.4	V	
Tx_Fault Output Current - High	I <sub>OH</sub>	-50	37.5	μ A	1
<b>Receiver</b>					
Data Output Differential Voltage	V <sub>OD</sub>	300	850	mV	2
Rx_LOS Output Voltage - Low	V <sub>OL</sub>	-0.3	0.4	V	
Rx_LOS Output Current - High	I <sub>OH</sub>	-50	37.5	μ A	1
SDA, SCL - Low	V <sub>IL</sub>	-0.3	V <sub>CC</sub> × 0.3	V	
SDA, SCL - High	V <sub>IH</sub>	V <sub>CC</sub> × 0.7	V <sub>CC</sub> + 0.5	V	

## TRANSMITTER ELECTRO-OPTICAL CHARACTERISTICS

PARAMETER	SYMBOL	MIN	TYP	MAX	UNIT	NOTE
Optical Output Power (average)	P <sub>o</sub>	-2		+2	dBm	
Center Wavelength Spacing			100		GHz	
			0.8		nm	
Spectral Width (-20dB)	Δ λ			1	nm	
Side Mode Suppression Ratio	SMSR	30			dB	
Transmitter OFF Power	P <sub>off</sub>			-30	dBm	
Transmitter Dispersion Penalty	TDP			2	dB	
Extinction Ratio	ER	8.2			dB	
Relative Intensity Noise(OMA)	RIN			-128	dB/Hz	

\* The laser shutdown is deactivated.

# 10 Gb/s Single Mode Transceiver



## RECEIVER ELECTRO-OPTICAL CHARACTERISTICS

PARAMETER	SYMBOL	MIN	TYP.	MAX	UNIT	NOTE
Maximum Input Optical Power	$P_{max}$	-1			dBm	
Receiver Sensitivity (Average)	$P_{min}$			-16	dBm	3
LOS of Signal - Deasserted	$P_D$			-16	dBm	
LOS of Signal - Asserted	$P_A$	-28			dBm	
LOS of Signal - Hysteresis	Hys	0.5			dB	
Reflectance	RL			-26	dB	
Operating Wavelength	$\lambda$	1260		1620	nm	

### Notes:

1. Measured with a 4.7k  $\Omega$  load pulled up to Vcc\_Host
2. Into 100  $\Omega$  differential termination
3. Measured with  $2^{31}-1$  PRBS at BER< $10^{-12}$

## TIMING CHARACTERISTICS

PARAMETER	SYMBOL	MIN	TYP.	MAX	UNIT	NOTE
TX_DISABLE Assert Time	$t_{off}$			10	$\mu$ s	
TX_DISABLE Negate Time	$t_{on}$			2	ms	
Time to initialize, include reset of TX_FAULT	$t_{init}$			300	ms	
TX_FAULT from fault to assertion	$t_{fault}$			100	$\mu$ s	
TX_DISABLE time to start reset	$t_{reset}$	10			$\mu$ s	
Receiver Loss of Signal Assert Time (off to on)	$t_{A,RX\_LOS}$			100	$\mu$ s	
Receiver Loss of Signal Assert Time (on to off)	$t_{D,RX\_LOS}$			100	$\mu$ s	

## DIGITAL DIAGNOSTIC MONITOR ACCURACY

PARAMETER	SYMBOL	MIN	MAX	UNIT	NOTE
Transceiver Temperature	T	-3	+3	$^{\circ}$ C	
Power Supply Voltage	V	-3	+3	%	
TX Bias Current	$T_x\_I$	-10	+10	%	
TX Optical Power	$T_x\_PWR$	-2	+2	dB	
RX Optical Power	$R_x\_PWR$	-3	+3	dB	

## BLOCK DIAGRAM OF TRANSCEIVER

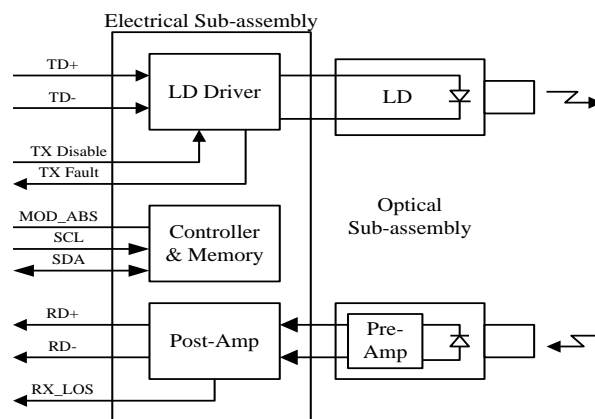

# 10 Gb/s Single Mode Transceiver



## PIN OUT DIAGRAM OF TRANSCEIVER

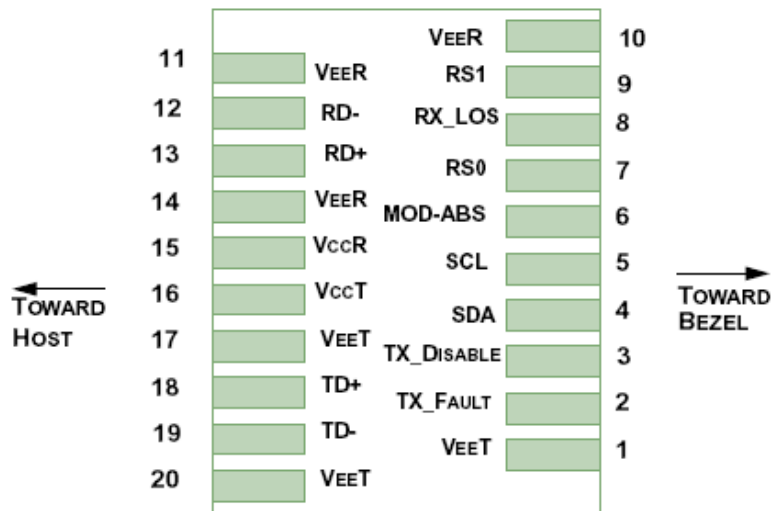

## PIN OUT TABLE

Pin	Symbol	Logic	Functional Description	Note
1	V <sub>EE</sub> T		Transmitter Ground	1
2	TX_FAULT	LVTTL-O	Transmitter Fault Indication	2
3	TX_DISABLE	LVTTL-I	Transmitter Disable – Module disables on high or open	3
4	SDA	LVTTL-I/O	Two wire serial ID interface data line	4
5	SCL	LVTTL-I/O	Two wire serial ID interface clock	4
6	MOD-ABS		Module absent, connect to V <sub>ee</sub> T or V <sub>ee</sub> R in the module	5
7	RS0		No connection required	
8	RX_LOS	LVTTL-O	Loss of Signal	2
9	RS1		No connection required	
10	V <sub>EE</sub> R		Receiver Ground	1
11	V <sub>EE</sub> R		Receiver Ground	1
12	RD-	CML-O	Inverse Received Data Out	
13	RD+	CML-O	Received Data Out	
14	V <sub>EE</sub> R		Receiver Ground	1
15	V <sub>CC</sub> R		Receiver Power	
16	V <sub>CC</sub> T		Transmitter Power	
17	V <sub>EE</sub> T		Transmitter Ground	1
18	TD+	CML-I	Transmitter Data In	
19	TD-	CML-I	Inverse Transmitter Data In	
20	V <sub>EE</sub> T		Transmitter Ground	1

### Notes:

1. Module ground pins GND are isolated from the module case and chassis ground within the module.
2. This is an open collector/drain output that on the host board requires a 4.7-10k  $\Omega$  pull-up resistor to V<sub>cc</sub>\_Host.
3. This is an input contact with a 4.7-10k  $\Omega$  pull-up to V<sub>cc</sub> inside the module.
4. Two-wire serial interface clock and data lines require an external pull-up resistor dependant on the capacitance load.
5. This is a ground return that on the host board requires a 4.7-10k  $\Omega$  pull-up resistor to V<sub>cc</sub>\_Host.

# 10 Gb/s Single Mode Transceiver



## EEPROM Serial ID Memory Contents

Table 1 - EEPROM Serial ID Memory Contents (A0h)

Addr.	Field Size (Bytes)	Name of Field	Hex	Description
00	1	Identifier	0B	DWDM SFP+
01	1	Ext. Identifier	04	SFP function is defined by two-wire interface ID only
02	1	Connector	07	LC
03 ~ 10	8	Transceiver Codes	80 00 00 00 00 00 00 00	
11	1	Encoding	06	64B/66B
12	1	BR,nominal	67	10.3Gbps
13	1	Rate Identifier	00	
14	1	Length (SMF)-km	28	40KM
15	1	Length (SMF)-100m	FF	40000M
16	1	Length (50um,OM2)	00	
17	1	Length (62.5um,OM1)	00	
18	1	Length (50um,OM4 or copper)	00	
19	1	Length (50um, OM3)	00	
20 ~ 35	16	Vendor Name	43 4F 52 45 54 45 4B 20 20 20 20 20 20 20 20 20	CORETEK
36	1	Transceiver Codes	00	
37 ~ 39	3	OUI Code	00 00 00	
40 ~ 55	16	Vendor PN	43 54 2D 41 30 30 30 54 50 50 2D 44 42 36 4C 45	CT-A000TPP-DB6LE
56 ~ 59	4	Vendor Rev	31 20 20 20	1000
60 ~ 61	2	DWDM Wavelength	XX XX	XXXX nm
62	1	DWDM Wavelength Fraction	YY	XXXX.YYnm
63	1	CC BASE	XX	Check sum
64 ~ 65	2	Options	3C 1A	Power Level 3, CDR indicator, Cooled Transceiver, LOS, TX_FAULT and TX_DISABLE
66	1	BR max	04	
67	1	BR min	05	
68 ~ 83	16	Vendor SN	XXXXXXXXXXXXXXXXXXXX	
84 ~ 91	8	Date code		
92	1	Diagnostic Monitoring Type	68	
93	1	Enhanced Options	90	
94	1	SFF-8472	08	
95	1	CC BASE	XX	Check sum
96 ~ 127	32	Vendor Specific		

# 10 Gb/s Single Mode Transceiver



Table 2- EEPROM Serial ID Memory Contents (A2h)

Addr.	Field Size (Bytes)	Name of Field	Hex	Description
00 ~ 07	8	Temperature Alarm/Warning (°C)	64 00 DB 00 5A 00 DD 00	Alarm_H/L : 100/-40 Warning_H/L : 90/-35
08 ~ 15	8	Voltage Alarm/Warning (V)	8C A0 75 30 88 B8 79 18	Alarm_H/L : 3.6/3 Warning_H/L : 3.5/3.1
16 ~ 23	8	Bias Current Alarm/Warning (mA)	C3 50 03 E8 AF C8 07 D0	Alarm_H/L : 100/2 Warning_H/L : 90/4
24 ~ 31	8	Tx Power Alarm/Warning (dBm)	3D E9 18 A6 37 2D 1B A7	Alarm_H/L : 2/-2 Warning_H/L : 1.5/-1.5
32 ~ 39	8	Rx Power Alarm/Warning (dBm)	1F 07 00 FB 1B A7 01 1A	Alarm_H/L : -1/-16 Warning_H/L : -1.5/-15.5
40 ~ 47	8	Laser Temp. Alarm/Warning (°C)	5A 00 19 00 55 00 1E 00	Alarm_H/L : 90/25 Warning_H/L : 85/30
48 ~ 55	8	TEC Current Alarm/Warning (mA)	1B 58 E4 A8 17 70 E8 90	Alarm_H/L : 700/-700 Warning_H/L : 600/-600



# 10 Gb/s Single Mode Transceiver



## RECOMMENDED CIRCUIT SCHEMATIC

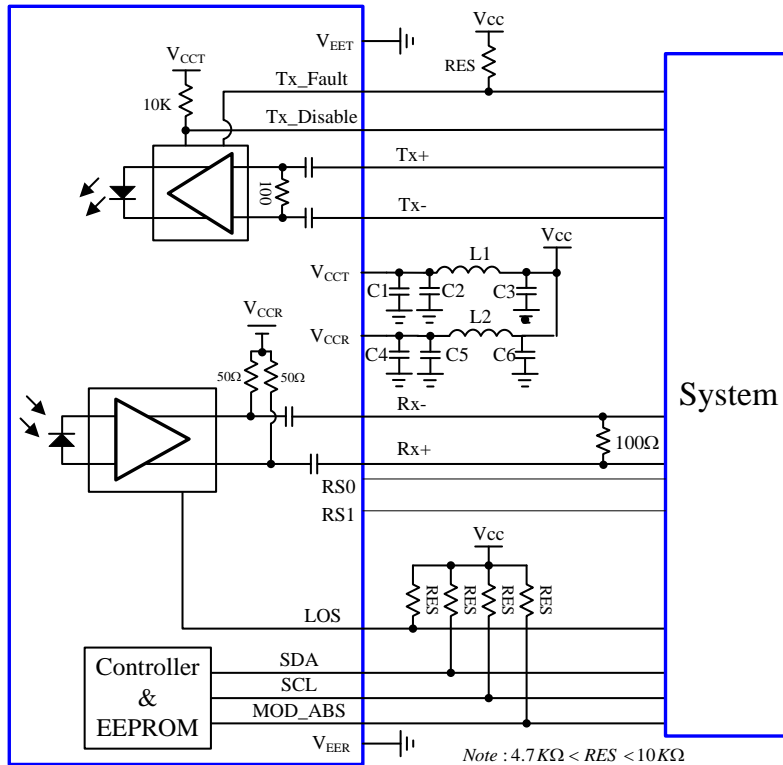

## MECHANICAL DIMENSIONS

Units in mm

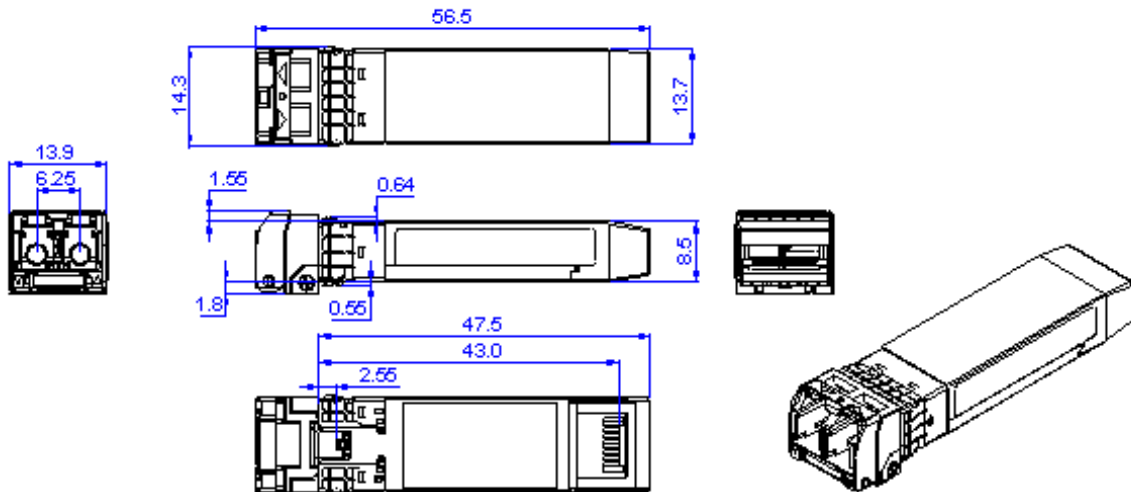

All dimensions are  $\pm 0.2\text{mm}$  unless otherwise specified.

## REVISION HISTORY

Formulate (Revise) Record		
D/M/Y	Version	Description
11/04/2019	A	Initial version
29/04/2019	A1	Change mechanical drawing and add A0h & A2h contents

**Claim:**

*CORETEK Opto Corp. reserves the right to make changes in the specification described hereinafter without prior notice.*