

# 1.25 Gigabit Ethernet-Multimode Transceiver

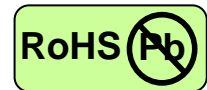

2×9 (12-pin), Duplex SC Connector, 1550nm DFB LD for Single Mode Fiber, RoHS Compliant  
Digital Diagnostics Functions, Extended Operating Temperature from -40 to +85°C

Preliminary Data Sheet



## Applications

- Gigabit Ethernet links
- Fibre Channel links at 1.06 Gbps
- High speed backplane interconnects
- Switched backbones

## Features

- 1550nm DFB LD
- Data Rate: 1.25Gbps, NRZ
- Single +3.3 V Power Supply
- RoHS Compliant and Lead-free
- AC/AC Differential Electrical Interface
- TTL Signal Detect Output
- 2×9 (12-pin) Footprint
- Duplex SC Connector
- Compliance with specifications for IEEE-802.3z Gigabit Ethernet (1000Base-SX) at 1.25 Gbps
- Compliance with ANSI specifications for Fibre Channel applications at 1.06 Gbps
- Compliant with SFF-8472 Digital Diagnostic Monitoring Interface
- Eye Safety  
Designed to meet Laser Class 1 comply with EN60825-1

## Description

The CT-1250TUR-KB6C-E from Coretek Opto Corp. are the high performance and cost-effective modules for serial optical data communication applications specified for multimode of 1.25 Gb/s. It operates with +3.3V power supply. The module is intended for multimode fiber, operates at a nominal wavelength of 1310nm and complies with the industry standard 2x9 footprint. Each module is integrated digital diagnostics functions via an I<sup>2</sup>C serial interface.

The module is a dual fiber connector transceiver designed for use in Gigabit Ethernet applications and to provide IEEE-802.3z compliant link for 1.25Gb/s short reach applications. The characteristics are performed in accordance with Telcordia Specification GR-468-CORE.

## EMC

Most equipment utilizing high-speed transceivers will be required to meet the following requirements:

- 1) FCC in the United States
- 2) CENELEC EN55022 (CISPR 22) in Europe

To assist the customer in managing the overall equipment EMC performance, the transceivers have been designed to satisfy FCC class B limits and provide good immunity to radio-frequency electromagnetic fields.

## Eye Safety

This laser based single mode transceiver is a CLASS 1 LASER PRODUCT, Hazard level 1. It complies with IEC 60825-1 Ed.2: 2007-03 and FDA performance standards for laser products (21 CFR 1040.10 and 1040.11) except for deviations pursuant to Laser Notice 50, dated June 24, 2007.

# 1.25 Gigabit Ethernet-Multimode Transceiver



## Product Information

Model Number	Operating Voltage & SD Output	Distance	Wavelength	Output Power	Sensitivity
CT-1250TUR-KB6C-E	3.3V TTL AC/AC	40km	1550 nm	-5 ~ 0 dBm	≤-23 dBm

## ABSOLUTE MAX RATINGS

PARAMETER	SYMBOL	MIN	MAX	UNIT	NOTE
Storage Temperature	T <sub>S</sub>	-40	85	°C	
Supply Voltage	V <sub>CC</sub>	0	6	V	
Lead Soldering Temperature/Time	T <sub>SOLD</sub>		260	°C	10 sec on lead
Data Input Voltage	---	0	V <sub>CC</sub>	V	

## OPERATING CONDITIONS

PARAMETER	SYMBOL	MIN.	TYP.	MAX.	UNIT	NOTE
Ambient Operating Temperature	T <sub>A</sub>	-40		85	°C	
Supply Voltage (for 3.3V)	V <sub>CC</sub>	3.10		3.50	V	
Supply Voltage (for 5.0V)	V <sub>CC</sub>	4.75		5.25	V	

## ELECTRICAL CHARACTERISTICS

PARAMETER	SYMBOL	MIN	MAX	UNIT	NOTE
<b>Transmitter</b>					
Transmitter Supply Current	I <sub>CCT</sub>		200	mA	
Tx_Disable Input Voltage - Low	V <sub>IL</sub>	0	0.8	V	
Tx_Disable Input Voltage - High	V <sub>IH</sub>	2.0	V <sub>CC</sub>	V	
Data Input Voltage Swing	V <sub>ID</sub>	400	1660	mV	
<b>Receiver</b>					
Receiver Supply Current	I <sub>CCR</sub>		100	mA	
Receiver Data Output Differential Voltage	V <sub>OD</sub>	0.4	1.3	V	
Signal Detect Output Voltage – Low	V <sub>OL</sub>		0.4	V	
Signal Detect Output Voltage – High	V <sub>OH</sub>	2.4		V	

## TRANSMITTER ELECTRO-OPTICAL CHARACTERISTICS

PARAMETER	SYMBOL	MIN	TYP.	MAX	UNIT	NOTE
Optical Output Power	P <sub>o</sub>	-5		0	dBm	1
Extinction Ratio	ER	9			dB	
Center Wavelength	λ <sub>c</sub>	1530	1550	1570	nm	
Spectral Width (RMS)	Δλ			1	nm	
Side Mode Suppression Ratio	SMSR	30			dB	
RIN	RIN			-117	dB/Hz	
Optical Rise time ( 20%-80% )	t <sub>r</sub>			260	ps	2
Optical Fall time ( 20%-80% )	t <sub>f</sub>			260	ps	2
Output Eye		Compliant with IEEE802.3z/D5.0				

# 1.25 Gigabit Ethernet-Multimode Transceiver



## RECEIVER ELECTRO-OPTICAL CHARACTERISTICS

PARAMETER	SYMBOL	MIN	TYP.	MAX	UNIT	NOTE
Maximum Input Optical Power	$P_{max}$	-3			dBm	3
Receiver Sensitivity	$P_{min}$			-23	dBm	3
Operating Wavelength	$\lambda$	1100		1600	nm	
Optical Return Loss	ORL	12			dB	
Receiver Electrical 3dB Upper Cutoff Frequency	---			1500	MHz	
Signal Detect - Asserted	$P_A$			-22	dBm	4
Signal Detect - Deasserted	$P_D$	-35			dBm	5

### Notes:

1. Measured average power coupled into 9/125  $\mu$  m single mode fiber.
2. These are 20-80% values.
3. Measured with  $2^7-1$  PRBS at  $BER < 10^{-12}$
4. Measured on transition – low to high
5. Measured on transition – high to low

## BLOCK DIAGRAM OF TRANSCEIVER

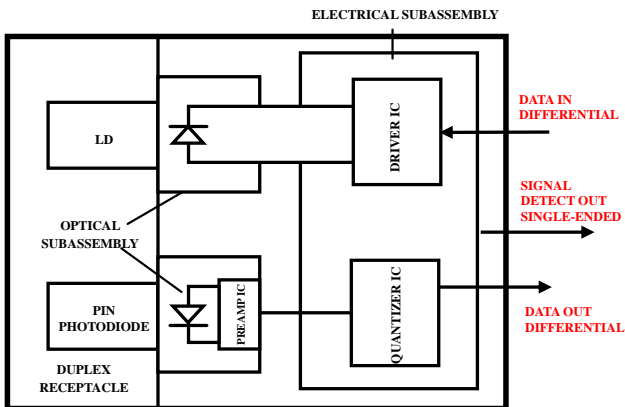

## PIN OUT DIAGRAM OF TRANSCEIVER

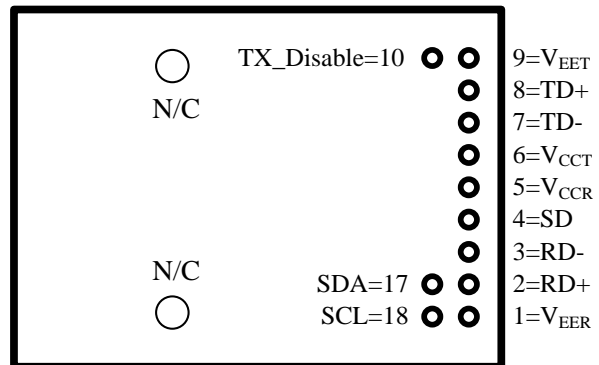

## PIN OUT TABLE

Pin	Symbol	Functional Description
Mounting Posts		
The mounting posts are provided for transceiver mechanical attachment to the circuit board. They should not be connected to the circuit ground but can be connected to the chassis ground.		
1	$V_{EER}$	Receiver Signal Ground
2	RD+	Receiver Data Non-inverted Differential Output
3	RD-	Receiver Data Inverted Differential Output
4	SD	Signal Detect is a PECL output. A high level indicates a received optical signal
5	$V_{CCR}$	Receiver Power Supply
6	$V_{CCT}$	Transmitter Power Supply
7	TD-	Transmitter Data Inverted Differential Input
8	TD+	Transmitter Data Non-inverted Differential Input
9	$V_{EET}$	Transmitter Signal Ground
10	TX Disable	Transmitter Disable – Module disables on high or open
17	SDA	Two wire serial ID interface - Data
18	SCL	Two wire serial ID interface - Clock

# 1.25 Gigabit Ethernet-Multimode Transceiver



## EEPROM Serial ID Memory Contents

Table 1 - EEPROM Serial ID Memory Contents (A0h)

Addr.	Field Size (Bytes)	Name of Field	Hex	Description
00	1	Identifier	02	Module/connector soldered to motherboard
01	1	Ext. Identifier	04	MOD4
02	1	Connector	01	SC
03 ~ 10	8	Transceiver Codes	00 00 00 02 12 00 01 01	
11	1	Encoding	01	8B/10B
12	1	BR,nominal	0D	
13	1	Reserved	00	
14	1	Length (SMF)-km	28	40KM
15	1	Length (SMF)-100m	FF	40000m
16	1	Length (50um,OM2)	00	
17	1	Length (62.5um,OM1)	00	
18	1	Length (copper)	00	
19	1	Length (50um, OM3)	00	
20 ~ 35	16	Vendor Name	43 4F 52 45 54 45 4B 20 20 20 20 20 20 20 20 20	CORETEK
36	1	Unallocated	00	
37 ~ 39	3	OUI Code	00 00 00	
40 ~ 55	16	Vendor PN	43 54 2D 31 32 35 30 54 55 52 2D 4B 42 36 4C 45	CT-1250TUR-KB6C-E
56 ~ 59	4	Vendor Rev	30 30 30 31	0001
60 ~ 61	2	Wavelength	06 0E	1550 nm
62	1	Reserved	00	
63	1	CC BASE	XX	Check sum
64 ~ 65	2	Options	00 1A	LOS, TX_FAULT and TX_DISABLE
66	1	BR max	00	
67	1	BR min	00	
68 ~ 83	16	Vendor SN	XXXXXXXXXXXXXXXXXX	
84 ~ 91	8	Date code		

# 1.25 Gigabit Ethernet-Multimode Transceiver



92	1	Diagnostic Monitoring Type	68	
93	1	Enhanced Options	90	
94	1	SFF-8472	01	Rev 9.3 of SFF-8472 Compliance
95	1	CC BASE	XX	Check sum
96 ~ 127	32	Vendor Specific		

**Table 2- EEPROM Serial ID Memory Contents (A2h)**

Addr.	Field Size (Bytes)	Name of Field	Hex	Description
00 ~ 07	8	Temperature Alarm/Warning (°C)	55 00 D8 00 50 00 DD 00	Alarm_H/L : 85/-40 Warning_H/L : 80/-35
08 ~ 15	8	Voltage Alarm/Warning (V)	8C A0 75 30 88 B8 79 18	Alarm_H/L : 3.6/3 Warning_H/L : 3.5/3.1
16 ~ 23	8	BiasCurrent Alarm/Warning (mA)	9C 40 03 E8 88 B8 07 D0	Alarm_H/L : 80/2 Warning_H/L : 70/4
24 ~ 31	8	Tx Power Alarm/Warning (dBm)	31 2D 09 D0 27 10 0C 5A	Alarm_H/L : +1/-6 Warning_H/L : 0/-5
32 ~ 39	8	Rx Power Alarm/Warning (dBm)	18 A6 00 28 13 94 00 32	Alarm_H/L : -2/-24 Warning_H/L : -3/-23
128 ~ 143	16	Vendor Specific		

## Monitoring Specification

The digital diagnostic monitoring interface also defines another 256-byte memory map in EEPROM, which makes use of the 8 bit address 1010001X(A2h). Please see Figure 1. For detail EEPROM information, please refer to the related document of SFF-8472 Rev 9.5. The monitoring specification of this product is described in Table3.

**Figure 3.1: Digital Diagnostic Memory Map**

### Specific Data Field Descriptions

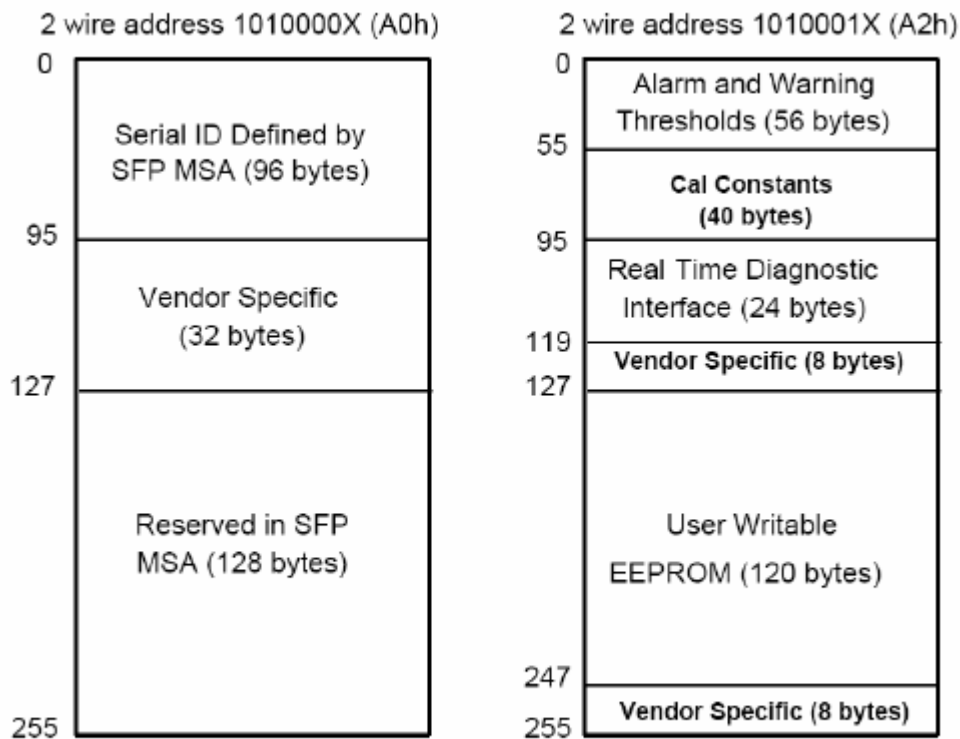

**Figure 1, EEPROM Memory Map Specific Data Field Descriptions**

**Table3 - Monitoring Specification**

Parameter	Range	Accuracy	Calibration
Temperature	-40°C to 85°C	±3°C	Internal
Voltage	3.0 to 3.6V	±3%	Internal
Bias Current	0 to 100 mA	±10%	Internal
TX Power	-6 to +1 dBm	±3dB	Internal
RX Power	-24 to -2 dBm	±3dB	Internal

# 1.25 Gigabit Ethernet-Multimode Transceiver



## RECOMMENDED CIRCUIT SCHEMATIC

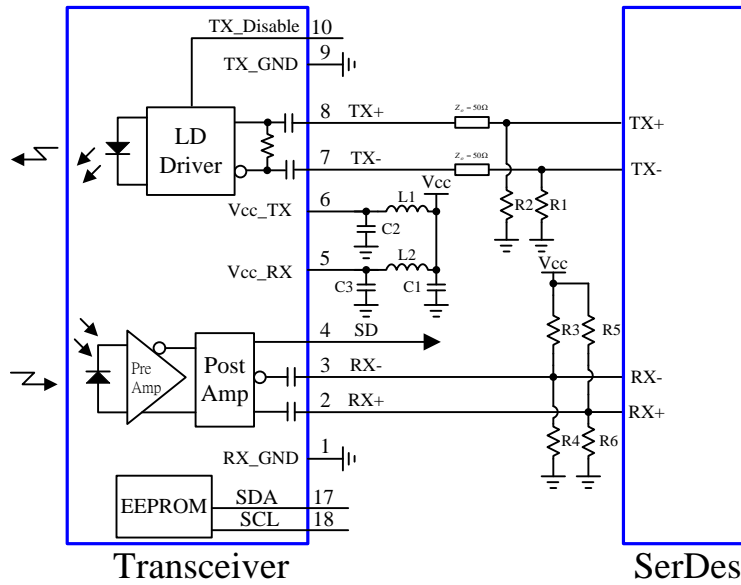

$C1 = 4.7\mu F$      $L1/L2 = 1\mu H$      $C2/C3 = 0.1\mu F$   
 $R1/R2/R3/R4/R5/R6$  depend on system chip

## MECHANICAL DIMENSIONS

Units in mm

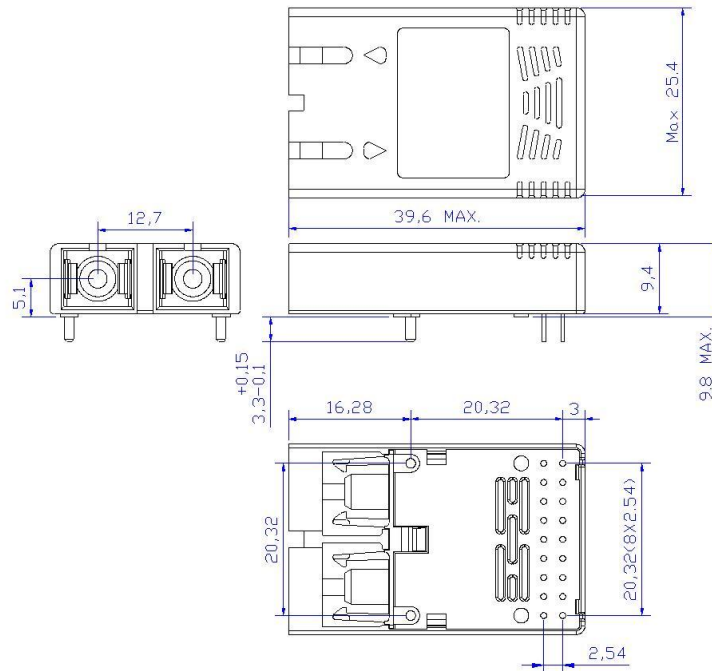

All dimensions are  $\pm 0.1$ mm unless otherwise specified.

### Claim:

CORETEK Opto Corp. reserves the right to make changes in the specification described hereinafter without prior notice.