

1.25 Gigabit Ethernet-Single Mode Transceiver

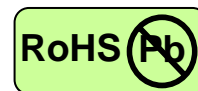

1×9, Duplex SC Connector, 1550nm DFB LD for Single Mode Fiber, RoHS Compliant



Features

- 1550nm DFB LD
- Data Rate: 1.25Gbps, NRZ
- Single +3.3V or +5V Power Supply
- RoHS Compliant and Lead-free
- DC/DC Differential Electrical Interface for SD PECL
- AC/AC Differential Electrical Interface for SD TTL
- Industry Standard 1×9 Output Footprint
- Duplex SC Connector
- Compliance with specifications for IEEE-802.3z Gigabit Ethernet at 1.25 Gbps
- Compliance with ANSI specifications for Fibre Channel applications at 1.06 Gbps
- Eye Safety
Designed to meet Laser Class 1 comply with EN60825-1

Applications

- Gigabit Ethernet links
- Fibre Channel links at 1.06 Gbps
- High speed backplane interconnects
- Switched backbones

Description

The CT-1250TTR-KBAC series from Coretek Opto Corp. are the high performance and cost-effective modules for serial optical data communication applications specified for single mode of 1.25 Gb/s. It operates with +5V or +3.3V power supply. The module is intended for single-mode fiber, operates at a nominal wavelength of 1550nm and complies with the industry standard 1x9 footprint. Each module consists of a transmitter optical subassembly, a receiver optical subassembly and an electrical subassembly. All of them are housed in a plastic package and the combination produces a reliable component.

The module is a dual fiber connector transceiver designed for use in Gigabit Ethernet applications and to provide IEEE-802.3z compliant link for 1.25Gb/s long reach applications. The characteristics are performed in accordance with Telcordia Specification GR-468-CORE.

EMC

Most equipment utilizing high-speed transceivers will be required to meet the following requirements:

- 1) FCC in the United States
- 2) CENELEC EN55022 (CISPR 22) in Europe

To assist the customer in managing the overall equipment EMC performance, the transceivers have been designed to satisfy FCC class B limits and provide good immunity to radio-frequency electromagnetic fields.

Eye Safety

The transceivers have been designed to meet Class 1 eye safety and comply with EN 60825-1.

1.25 Gigabit Ethernet-Single Mode Transceiver



Product Information

Model Number	Operating Voltage & SD Output	Distance	LD Type & Wavelength	Output Power	Sensitivity
CT-1250TTR-KBAC	3.3V TTL AC/AC	120 km	1550 nm DFB	0 ~ +5 dBm	≤ -32 dBm

ABSOLUTE MAX RATINGS

PARAMETER	SYMBOL	MIN	MAX	UNIT	NOTE
Storage Temperature	T_S	-40	85	$^{\circ}\text{C}$	
Supply Voltage	V_{CC}	0	6	V	
Lead Soldering Temperature/Time	T_{SOLD}		260	$^{\circ}\text{C}$	10 sec on lead
Data Input Voltage	---	0	V_{CC}	V	

OPERATING CONDITIONS

PARAMETER	SYMBOL	MIN.	TYP.	MAX.	UNIT	NOTE
Ambient Operating Temperature	T_A	0		70	$^{\circ}\text{C}$	
Supply Voltage (for 3.3V)	V_{CC}	3.10		3.50	V	
Supply Voltage (for 5.0V)	V_{CC}	4.75		5.25	V	
Data Input Voltage Swing	V_{ID}	400		1660	mV	

ELECTRICAL CHARACTERISTICS

PARAMETER	SYMBOL	MIN	MAX	UNIT	NOTE
Transmitter					
Transmitter Supply Current	I_{CCT}		200	mA	
Transmitter Data Input Current – Low	I_{IL}	-350		μA	
Transmitter Data Input Current – High	I_{IH}		350	μA	
Transmitter Data Input Voltage – Low	$V_{IL}-V_{CC}$	-1.84	-1.6	V	
Transmitter Data Input Voltage – High	$V_{IH}-V_{CC}$	-1.1	-0.9	V	
Receiver					
Receiver Supply Current	I_{CCR}		100	mA	
Receiver Data Output Voltage – Low	$V_{OL}-V_{CC}$	-1.84	-1.6	V	1
Receiver Data Output Voltage – High	$V_{OH}-V_{CC}$	-1.1	-0.9	V	1
Signal Detect Output Voltage – Low (for PECL)	$V_{OL}-V_{CC}$	-1.84	-1.6	V	1
Signal Detect Output Voltage – High (for PECL)	$V_{OH}-V_{CC}$	-1.1	-0.9	V	1
Signal Detect Output Voltage – Low (for TTL)	V_{OL}		0.8	V	
Signal Detect Output Voltage – High (for TTL)	V_{OH}	2.0		V	

1.25 Gigabit Ethernet-Single Mode Transceiver



TRANSMITTER ELECTRO-OPTICAL CHARACTERISTICS

PARAMETER	SYMBOL	MIN	TYP.	MAX	UNIT	NOTE
Optical Output Power	P _o	-2		3	dBm	2
Extinction Ratio	ER	9			dB	
Center Wavelength	λ_c	1530	1550	1570	nm	
Spectral Width (-20dB)	$\Delta \lambda$			1	nm	
Side Mode Suppression Ratio	SMSR	30			dB	
RIN	RIN			-120	dB/Hz	
Optical Rise time (20%-80%)	t _r			260	ps	3
Optical Fall time (20%-80%)	t _f			260	ps	3
Output Eye						Compliant with IEEE802.3z/D5.0

RECEIVER ELECTRO-OPTICAL CHARACTERISTICS

PARAMETER	SYMBOL	MIN	TYP.	MAX	UNIT	NOTE
Maximum Input Optical Power	P _{max}	-9			dBm	4
Receiver Sensitivity	P _{min}			-32	dBm	4
Operating Wavelength	λ	1100		1600	nm	
Optical Return Loss	ORL	12			dB	
Receiver Electrical 3dB Upper Cutoff Frequency	---			1500	MHz	
Signal Detect - Asserted	P _A			-32	dBm	5
Signal Detect - Deasserted	P _D	-43			dBm	6

Notes:

1. These outputs are compatible with 10K, 10KH, 100K ECL and PECL inputs.
2. Measured average power coupled into 9/125 μ m single-mode fiber.
3. These are 20-80% values.
4. Measured with 2⁷-1 PRBS at BER<10⁻¹²
5. Measured on transition – low to high
6. Measured on transition – high to low

1.25 Gigabit Ethernet-Single Mode Transceiver



BLOCK DIAGRAM OF TRANSCEIVER

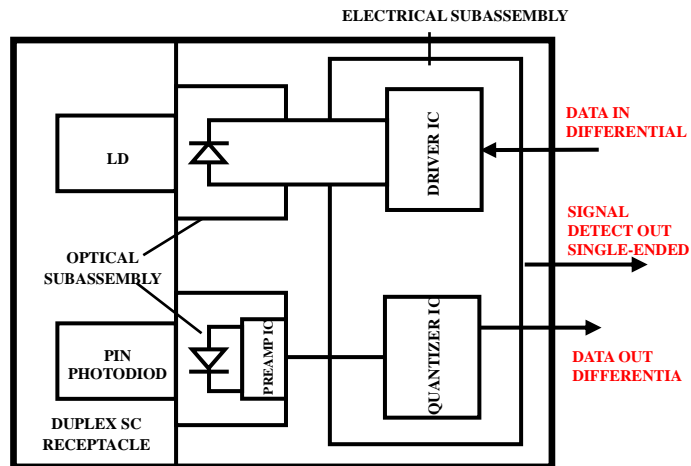

PIN OUT DIAGRAM OF TRANSCEIVER

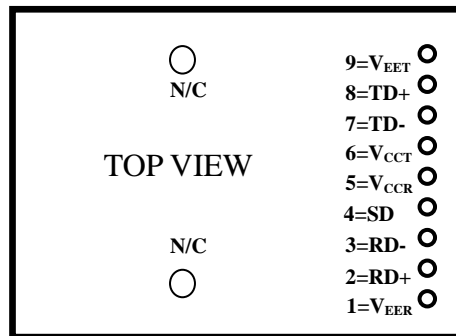

PIN OUT TABLE

Pin	Symbol	Functional Description
Mounting Posts		
The mounting posts are provided for transceiver mechanical attachment to the circuit board. They should not be connected to the circuit ground but can be connected to the chassis ground.		
1	V _{EER}	Receiver Signal Ground
2	RD+	Receiver Data Non-inverted Differential Output
3	RD-	Receiver Data Inverted Differential Output
4	SD	Signal Detect is a PECL or TTL output. A high level indicates a received optical signal
5	V _{CCR}	Receiver Power Supply
6	V _{CCT}	Transmitter Power Supply
7	TD-	Transmitter Data Inverted Differential Input
8	TD+	Transmitter Data Non-inverted Differential Input
9	V _{EET}	Transmitter Signal Ground

1.25 Gigabit Ethernet-Single Mode Transceiver



RECOMMENDED CIRCUIT SCHEMATIC

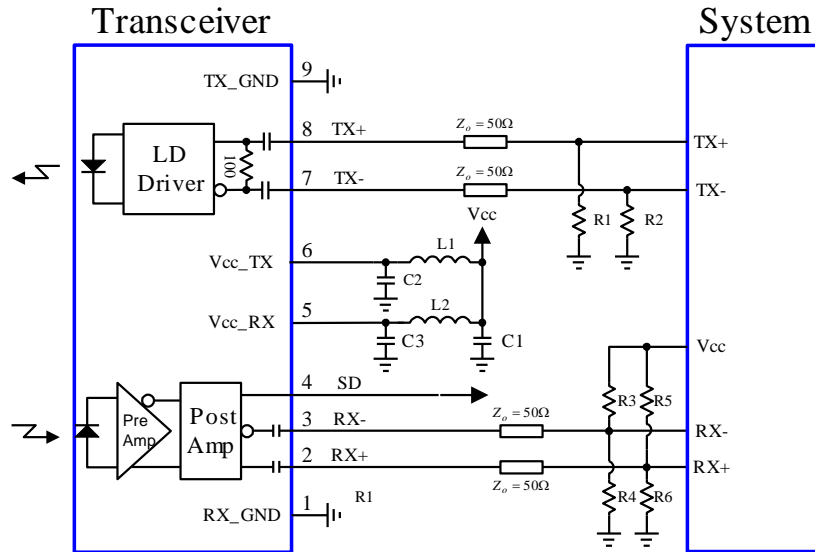

C1 = 4.7μ F L1/L2 = 1μ H C2/C3/C4/C5=0.1μ F
 R1,R2,R3,R4,R5,R6 depend on System chip

MECHANICAL DIMENSIONS

Units in mm

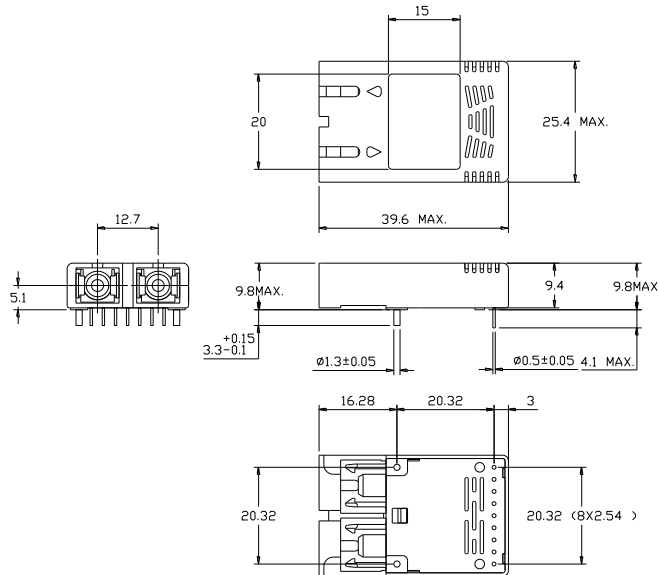

DIMENSIONS ARE IN MILLIMETERS.
 ALL DIMENSIONS ARE ± 0.1 mm UNLESS OTHERWISE SPECIFIED.

Claim:

CORETEK Opto Corp. reserves the right to make changes in the specification described hereinafter without prior notice.