

1.25 Gigabit Ethernet-Single Mode Transceiver

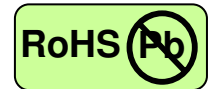

1×9, Duplex SC Connector, CWDM LD for Single Mode Fiber, RoHS Compliant
Power Budget 19dB



Features

- CWDM 8 wavelengths Transmitter
- Data Rate: 1.25Gbps, NRZ
- Single +3.3V or +5V Power Supply
- RoHS Compliant and Lead-free
- DC/DC Differential Electrical Interface for SD PECL
- AC/AC Differential Electrical Interface for SD TTL
- Industry Standard 1×9 Output Footprint
- Duplex SC Connector
- Compliance with specifications for IEEE-802.3z Gigabit Ethernet at 1.25 Gbps
- Compliance with ANSI specifications for Fiber Channel applications at 1.06 Gbps
- Eye Safety
Designed to meet Laser Class 1 comply with EN60825-1

Applications

- CWDM
- Gigabit Ethernet links
- Fiber Channel links at 1.06 Gbps
- High speed backplane interconnects
- Switched backbones

Description

The CT-1250TTR-Cx6C series from Coretek Opto Corp. are the high performance and cost-effective modules for serial optical data communication applications specified for single mode of 1.25 Gb/s. It operates with +5V or +3.3V power supply. The module is intended for single-mode fiber, operates at a nominal wavelength of CWDM and complies with the industry standard 1x9 footprint. Each module consists of a transmitter optical subassembly, a receiver optical subassembly and an electrical subassembly. All of them are housed in a plastic package and the combination produces a reliable component.

The module is a dual fiber connector transceiver designed for use in Gigabit Ethernet applications and to provide IEEE-802.3z compliant link for 1.25Gb/s long reach applications. The characteristics are performed in accordance with ITU-T G.694.2 and G.695.

EMC

Most equipment utilizing high-speed transceivers will be required to meet the following requirements:

- 1) FCC in the United States
- 2) CENELEC EN55022 (CISPR 22) in Europe

To assist the customer in managing the overall equipment EMC performance, the transceivers have been designed to satisfy FCC class B limits and provide good immunity to radio-frequency electromagnetic fields.

Eye Safety

The transceivers have been designed to meet Class 1 eye safety and comply with EN 60825-1.

1.25 Gigabit Ethernet-Single Mode Transceiver



Product Information

Model Number	Wavelength	Operating Voltage & SD Output	Distance	Output Power	Sensitivity
CT-1250TTR-C16C	1470 nm	5V PECL DC/DC	40 km	-5 ~ 0 dBm	≤ -24 dBm
	1490 nm				
	1510 nm				
	1530 nm				
	1550 nm				
	1570 nm				
	1590 nm				
CT-1250TTR-C26C	1470 nm	3.3V PECL DC/DC	40 km	-5 ~ 0 dBm	≤ -24 dBm
	1490 nm				
	1510 nm				
	1530 nm				
	1550 nm				
	1570 nm				
	1590 nm				
CT-1250TTR-CD6C	1470 nm	5V TTL AC/AC	40 km	-5 ~ 0 dBm	≤ -24 dBm
	1490 nm				
	1510 nm				
	1530 nm				
	1550 nm				
	1570 nm				
	1590 nm				
CT-1250TTR-CB6C	1470 nm	3.3V TTL AC/AC	40 km	-5 ~ 0 dBm	≤ -24 dBm
	1490 nm				
	1510 nm				
	1530 nm				
	1550 nm				
	1570 nm				
	1590 nm				
1610 nm					

ABSOLUTE MAX RATINGS

PARAMETER	SYMBOL	MIN	MAX	UNIT	NOTE
Storage Temperature	T _S	-40	85	°C	
Supply Voltage	V _{CC}	0	6	V	
Lead Soldering Temperature/Time	T _{SOLD}		260	°C	10 sec on lead
Data Input Voltage	---	0	V _{CC}	V	

OPERATING CONDITIONS

PARAMETER	SYMBOL	MIN.	TYP.	MAX.	UNIT	NOTE
Ambient Operating Temperature	T _A	0		70	°C	
Supply Voltage (for 3.3V)	V _{CC}	3.10		3.50	V	
Supply Voltage (for 5.0V)	V _{CC}	4.75		5.25	V	
Data Input Voltage Swing	V _{ID}	400		1660	mV	

1.25 Gigabit Ethernet-Single Mode Transceiver



ELECTRICAL CHARACTERISTICS

PARAMETER	SYMBOL	MIN	MAX	UNIT	NOTE
Transmitter					
Transmitter Supply Current	I_{CCR}		200	mA	
Transmitter Data Input Current – Low	I_{IL}	-350		μ A	
Transmitter Data Input Current – High	I_{IH}		350	μ A	
Transmitter Data Input Voltage – Low	$V_{IL}-V_{CC}$	-1.84	-1.6	V	
Transmitter Data Input Voltage – High	$V_{IH}-V_{CC}$	-1.1	-0.9	V	
Receiver					
Receiver Supply Current	I_{CCR}		100	mA	
Receiver Data Output Voltage – Low	$V_{OL}-V_{CC}$	-1.84	-1.6	V	1
Receiver Data Output Voltage – High	$V_{OH}-V_{CC}$	-1.1	-0.9	V	1
Signal Detect Output Voltage – Low (for PECL)	$V_{OL}-V_{CC}$	-1.84	-1.6	V	1
Signal Detect Output Voltage – High (for PECL)	$V_{OH}-V_{CC}$	-1.1	-0.9	V	1
Signal Detect Output Voltage – Low (for TTL)	V_{OL}		0.8	V	
Signal Detect Output Voltage – High (for TTL)	V_{OH}	2.0		V	

TRANSMITTER ELECTRO-OPTICAL CHARACTERISTICS

PARAMETER	SYMBOL	MIN	TYP.	MAX	UNIT	NOTE
Optical Output Power	P_o	-5		0	dBm	2
Extinction Ratio	ER	9			dB	
Center Wavelength	λ_c	1464.5	1470	1477.5	nm	
		1484.5	1490	1497.5		
		1504.5	1510	1517.5		
		1524.5	1530	1537.5		
		1544.5	1550	1557.5		
		1564.5	1570	1577.5		
		1584.5	1590	1597.5		
		1604.5	1610	1617.5		
Spectral Width (-20dB)	$\Delta \lambda$			1	nm	
Side Mode Suppression Ratio	SMSR	30			dB	
RIN	RIN			-120	dB/Hz	
Optical Rise time (20%-80%)	t_r			260	ps	3
Optical Fall time (20%-80%)	t_f			260	ps	3
Output Eye		Compliant with IEEE802.3z/D5.0				

RECEIVER ELECTRO-OPTICAL CHARACTERISTICS

PARAMETER	SYMBOL	MIN	TYP.	MAX	UNIT	NOTE
Maximum Input Optical Power	P_{max}	-3			dBm	4
Receiver Sensitivity	P_{min}			-24	dBm	4
Operating Wavelength	λ	1260		1620	nm	
Optical Return Loss	ORL	12			dB	
Receiver Electrical 3dB Upper Cutoff Frequency	---			1500	MHz	
Signal Detect - Asserted	P_A			-24	dBm	5
Signal Detect - Deasserted	P_D	-35			dBm	6

Notes:

1. These outputs are compatible with 10K, 10KH, 100K ECL and PECL inputs.
2. Measured average power coupled into 9/125 μ m single-mode fiber.
3. These are 20-80% values.
4. Measured with 2^7-1 PRBS at BER< 10^{-12}
5. Measured on transition – low to high
6. Measured on transition – high to low

1.25 Gigabit Ethernet-Single Mode Transceiver

BLOCK DIAGRAM OF TRANSCEIVER

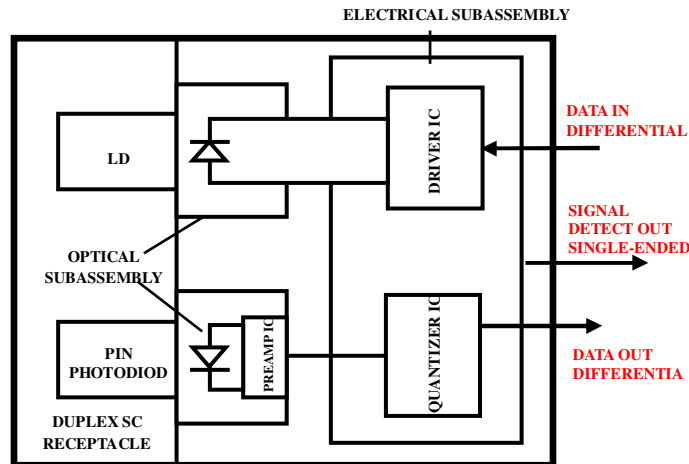

PIN OUT DIAGRAM OF TRANSCEIVER

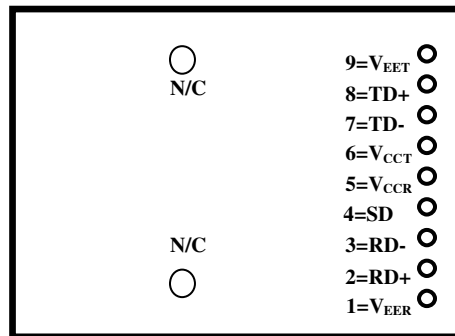

PIN OUT TABLE

Pin	Symbol	Functional Description
Mounting Posts		
The mounting posts are provided for transceiver mechanical attachment to the circuit board. They should not be connected to the circuit ground but can be connected to the chassis ground.		
1	V _{EER}	Receiver Signal Ground
2	RD+	Receiver Data Non-inverted Differential Output
3	RD-	Receiver Data Inverted Differential Output
4	SD	Signal Detect is a PECL or TTL output. A high level indicates a received optical signal
5	V _{CCR}	Receiver Power Supply
6	V _{CCT}	Transmitter Power Supply
7	TD-	Transmitter Data Inverted Differential Input
8	TD+	Transmitter Data Non-inverted Differential Input
9	V _{EET}	Transmitter Signal Ground

1.25 Gigabit Ethernet-Single Mode Transceiver



RECOMMENDED CIRCUIT SCHEMATIC

1) SD PECL DC/DC Module

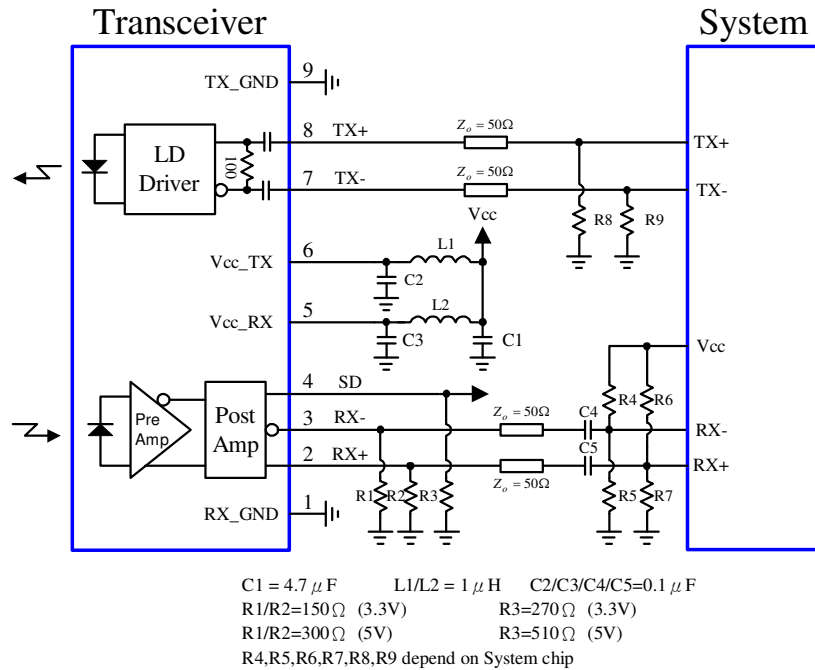

2) SD TTL AC/AC Module

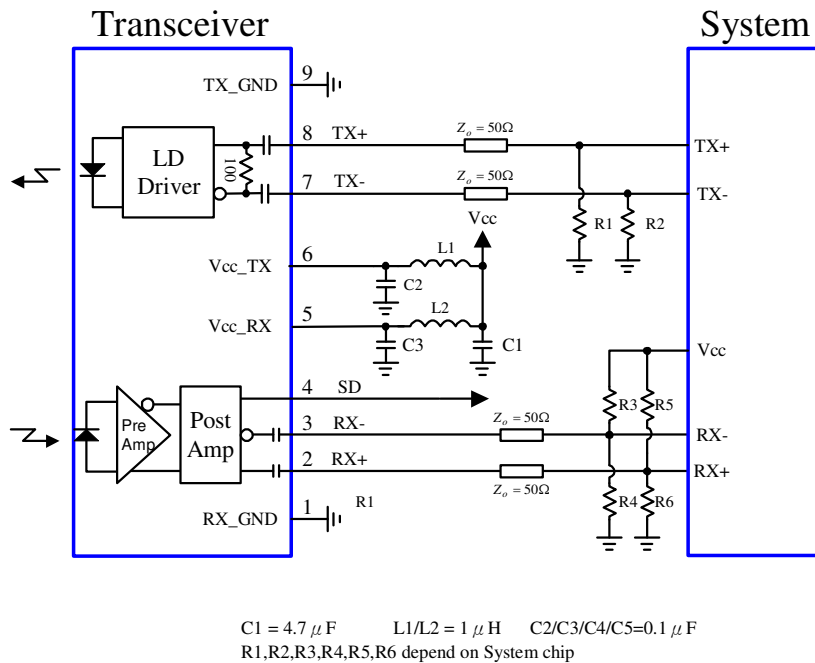

1.25 Gigabit Ethernet-Single Mode Transceiver



MECHANICAL DIMENSIONS

Units in mm

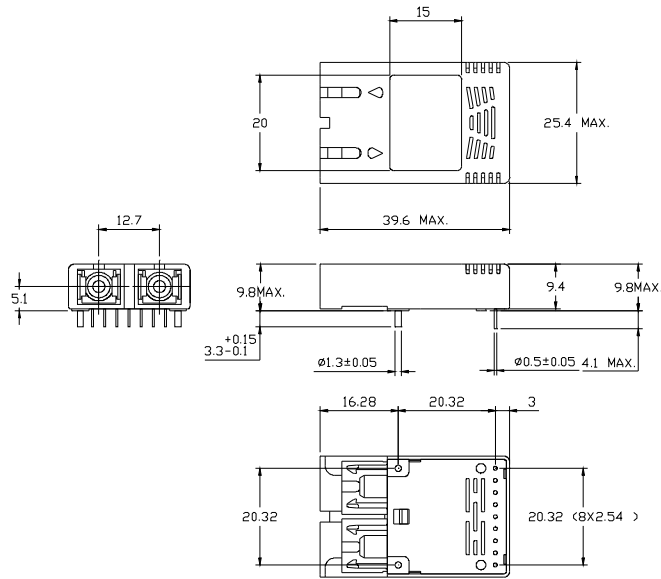

DIMENSIONS ARE IN MILLIMETERS.
ALL DIMENSIONS ARE ± 0.1 mm UNLESS OTHERWISE SPECIFIED.

Claim:

CORETEK Opto Corp. reserves the right to make changes in the specification described hereinafter without prior notice.