

# 1.25 Gigabit Ethernet-Single Mode Transceiver

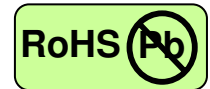

GBIC, Duplex SC Connector, 1310nm DFB LD for Single Mode Fiber, RoHS Compliant



## Features

- 1310nm DFB LD
- Data Rate: 1.25Gbps, NRZ
- Single +3.3V/5V Power Supply
- RoHS Compliant and Lead-free
- AC/AC Differential Electrical Interface
- Compliant with Gigabit Interface Converter (GBIC)
- Duplex SC Connector
- Compliance with specifications for IEEE-802.3z Gigabit Ethernet at 1.25 Gbps
- Compliance with ANSI specifications for Fibre Channel applications at 1.06 Gbps
- Eye Safety  
Designed to meet Laser Class 1 comply with EN60825-1

## Applications

- Gigabit Ethernet Links
- Fibre Channel Links at 1.06 Gbps
- High Speed Backplane Interconnects
- Switched Backbones

## Description

The CT-1250TGR-NC6C from Coretek Opto Corp. is a high performance and cost-effective module for serial optical data communication applications specified for single mode of 1.25 Gb/s. It operates with +3.3/5V power supply. The module is intended for single-mode fiber, operates at a nominal wavelength of 1310nm and complies with Gigabit Interface Converter (GBIC). Each module consists of a transmitter optical subassembly, a receiver optical subassembly and an electrical subassembly. All of them are housed in a metal package and the combination produces a reliable component.

The module is a duplex SC connector transceiver designed for use in Gigabit Ethernet applications and to provide IEEE-802.3z compliant link for 1.25Gb/s long reach applications. The characteristics are performed in accordance with Telcordia Specification GR-468-CORE.

## EMC

Most equipment utilizing high-speed transceivers will be required to meet the following requirements:

- 1) FCC in the United States
- 2) CENELEC EN55022 (CISPR 22) in Europe

To assist the customer in managing the overall equipment EMC performance, the transceivers have been designed to satisfy FCC class B limits and provide good immunity to radio-frequency electromagnetic fields.

## Eye Safety

The transceivers have been designed to meet Class 1 eye safety and comply with EN 60825-1.

# 1.25 Gigabit Ethernet-Single Mode Transceiver



## Product Information

Model Number	Operating Voltage & SD Output	Distance	LD Type & Wavelength	Output Power	Sensitivity
CT-1250TGR-NC6C	3.3/5V TTL AC/AC	40 km	1310 nm DFB	-3 ~ +2 dBm	$\leq -23$ dBm

## ABSOLUTE MAX RATINGS

PARAMETER	SYMBOL	MIN	MAX	UNIT	NOTE
Storage Temperature	T <sub>S</sub>	-40	85	°C	
Supply Voltage	V <sub>CC</sub>	0	6	V	
Data Input Voltage	---	0	V <sub>CC</sub>	V	
Supply Current	I <sub>S</sub>		300	mA	

## OPERATING CONDITIONS

PARAMETER	SYMBOL	MIN.	TYP.	MAX.	UNIT	NOTE
Case Operating Temperature	T <sub>A</sub>	0		70	°C	
Supply Voltage	V <sub>CC</sub>	3.10		5.25	V	
Data Input Voltage Swing	V <sub>ID</sub>	300		1860	mV	

## ELECTRICAL CHARACTERISTICS

PARAMETER	SYMBOL	MIN	MAX	UNIT	NOTE
<b>Transmitter</b>					
Transmitter Supply Current	I <sub>CC</sub> T		200	mA	
Tx_ Disable Input Voltage - Low	V <sub>IL</sub>	0	0.8	V	
Tx_ Disable Input Voltage - High	V <sub>IH</sub>	2.0	V <sub>CC</sub>	V	
Tx_ Fault Output Voltage - Low	V <sub>OL</sub>	0	0.8	V	
Tx_ Fault Output Voltage - High	V <sub>OH</sub>	2.0	V <sub>CC</sub>	V	
<b>Receiver</b>					
Receiver Supply Current	I <sub>CC</sub> R		100	mA	
Receiver Data Output Differential Voltage	V <sub>OD</sub>	0.4	1.3	V	
Rx_LOS Output Voltage - Low	V <sub>OL</sub>	0	0.8	V	
Rx_LOS Output Voltage - High	V <sub>OH</sub>	2.0	V <sub>CC</sub>	V	
MOD_DEF (1) , MOD_DEF (2) - Low	V <sub>IL</sub>	-0.6	V <sub>CC</sub> × 0.3	V	
MOD_DEF (1) , MOD_DEF (2) - High	V <sub>IH</sub>	V <sub>CC</sub> × 0.7	V <sub>CC</sub> + 0.5	V	

## TRANSMITTER ELECTRO-OPTICAL CHARACTERISTICS

PARAMETER	SYMBOL	MIN	TYP.	MAX	UNIT	NOTE
Optical Output Power	P <sub>O</sub>	-3		2	dBm	1
Extinction Ratio	ER	9			dB	
Center Wavelength	λ <sub>c</sub>	1290	1310	1325	nm	
Spectral Width (-20dB)	Δλ			1	nm	
Side Mode Suppression Ratio	SMSR	30			dB	
RIN	RIN			-117	dB/Hz	
Optical Rise time (20%-80% )	t <sub>r</sub>			260	ps	2
Optical Fall time (20%-80% )	t <sub>f</sub>			260	ps	2
Output Eye		Compliant with IEEE802.3z/D5.0				

# 1.25 Gigabit Ethernet-Single Mode Transceiver



## RECEIVER ELECTRO-OPTICAL CHARACTERISTICS

PARAMETER	SYMBOL	MIN	TYP.	MAX	UNIT	NOTE
Maximum Input Optical Power	$P_{max}$	-3			dBm	3
Minimum Input Optical Power	$P_{min}$			-23	dBm	3
Operating Wavelength	$\lambda$	1100		1600	nm	
Optical Return Loss	ORL	12			dB	
Receiver Electrical 3dB Upper Cutoff Frequency	---			1500	MHz	
LOS of Signal - Asserted	$P_A$	-35			dBm	
LOS of Signal - Deasserted	$P_D$			-23	dBm	
Loss of Signal -Hysterisis	$P_D - P_A$	0.5			dB	

### Notes:

1. Measured average power coupled into 9/125  $\mu$  m single mode fiber.
2. These are 20-80% values.
3. Measured with  $2^7-1$  PRBS at BER< $10^{-12}$

## TIMING CHARACTERISTICS

PARAMETER	SYMBOL	MIN	TYP.	MAX	UNIT	NOTE
TX_DISABLE Assert Time	$t_{off}$			10	$\mu$ s	
TX_DISABLE Negate Time	$t_{on}$			1	ms	
Time to initialize, include reset of TX_FAULT	$t_{init}$			300	ms	
TX_FAULT from fault to assertion	$t_{fault}$			100	$\mu$ s	
TX_DISABLE time to start reset	$t_{reset}$	10			$\mu$ s	
Receiver Loss of Signal Assert Time (off to on)	$t_{A,RX\_LOS}$			100	$\mu$ s	
Receiver Loss of Signal Assert Time (on to off)	$t_{D,RX\_LOS}$			100	$\mu$ s	

## BLOCK DIAGRAM OF TRANSCEIVER

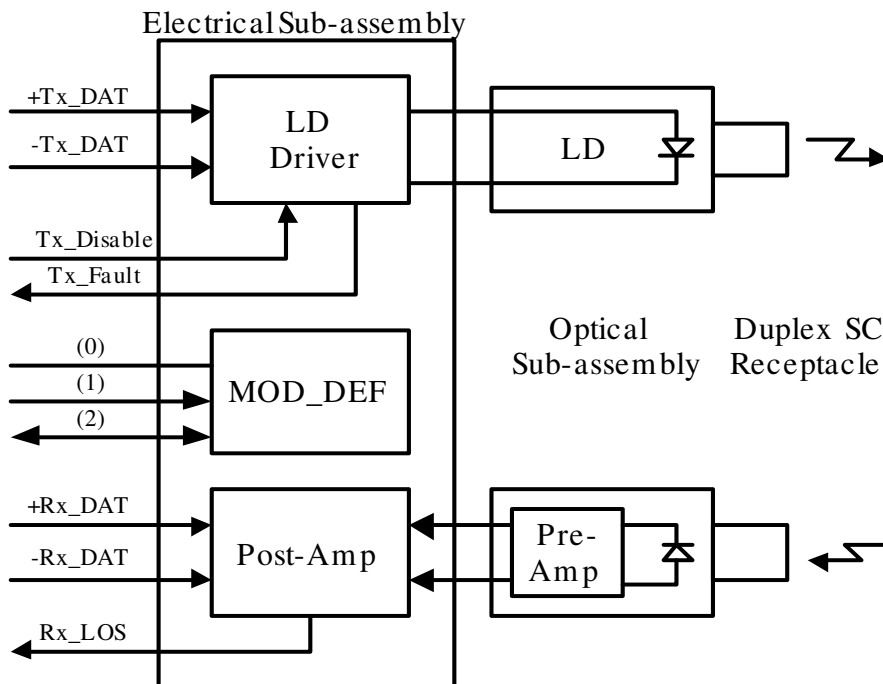

# 1.25 Gigabit Ethernet-Single Mode Transceiver



## PIN OUT DIAGRAM OF TRANSCEIVER

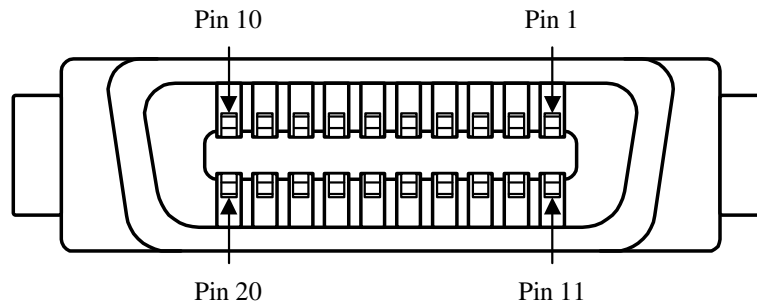

## PIN OUT TABLE

Pin	Symbol	Functional Description
1	Rx_LOS	Loss of Signal
2	RGND	Receiver Ground
3	RGND	Receiver Ground
4	MOD-DEF(0)	Module Definition 0 – Grounded in module
5	MOD-DEF(1)	Module Definition 1 – Two wire serial ID interface
6	MOD-DEF(2)	Module Definition 2 – Two wire serial ID interface
7	Tx_Disable	Transmitter Disable – Module disables on high or open
8	TGND	Transmitter Ground
9	TGND	Transmitter Ground
10	Tx_Fault	Transmitter Fault Indication
11	RGND	Receiver Ground
12	-Rx_DAT	Inverse Received Data Out
13	+Rx_DAT	Received Data Out
14	RGND	Receiver Ground
15	V <sub>DD</sub> R	Receiver Power
16	V <sub>DD</sub> T	Transmitter Power
17	TGND	Transmitter Ground
18	+Tx_DAT	Transmitter Data In
19	-Tx_DAT	Inverse Transmitter Data In
20	TGND	Transmitter Ground

# 1.25 Gigabit Ethernet-Single Mode Transceiver



## RECOMMENDED CIRCUIT SCHEMATIC

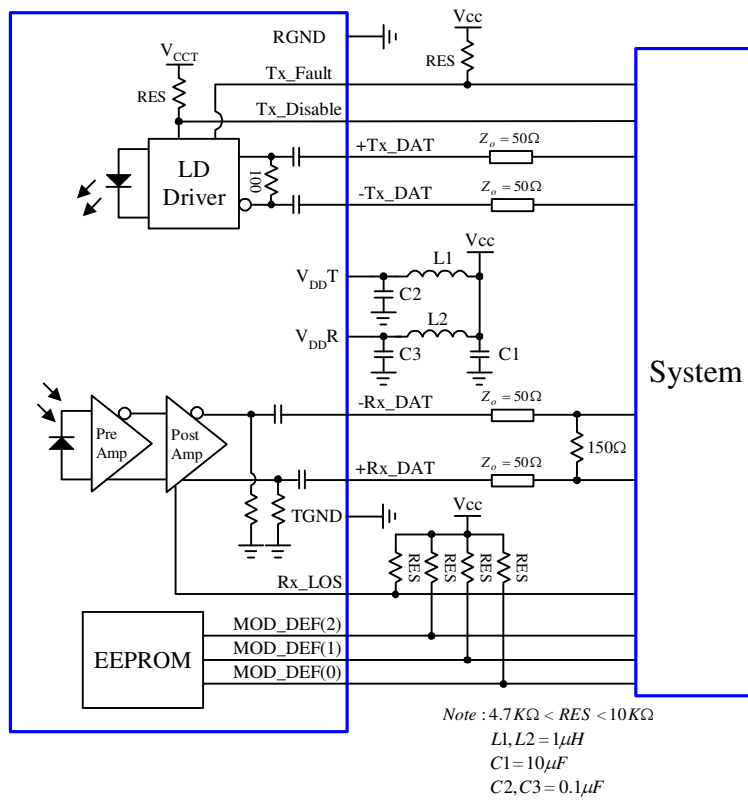

## MECHANICAL DIMENSIONS

Units in mm

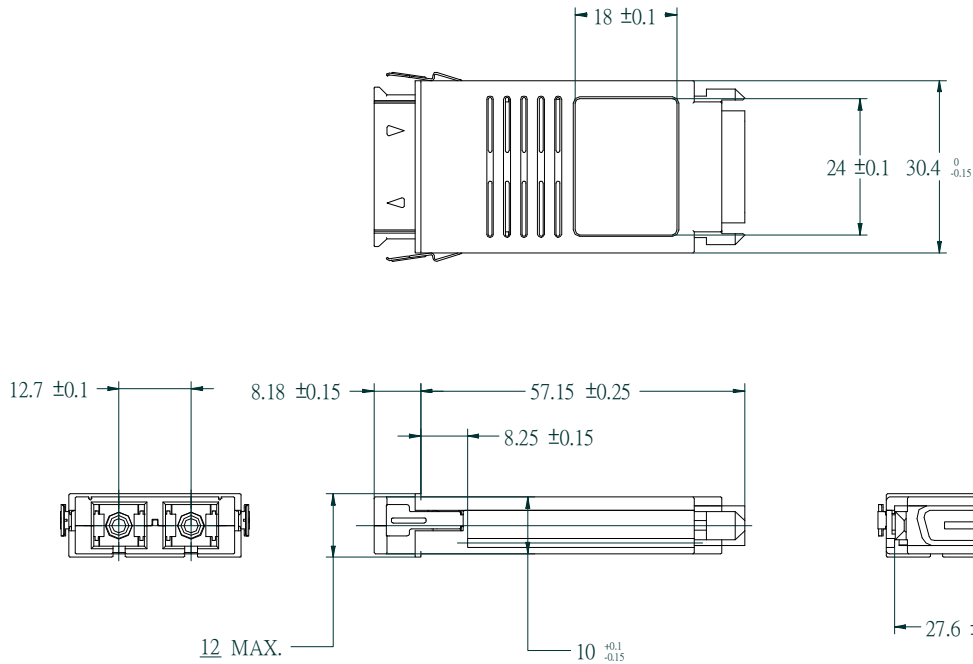

### Claim:

CORETEK Opto Corp. reserves the right to make changes in the specification described hereinafter without prior notice.