

# 1.25 Gigabit Ethernet-Single Mode Transceiver

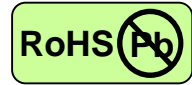

SFP BIDI, Single LC Connector, 1490nm DFB LD for Single Mode Fiber, RoHS Compliant  
Digital Diagnostics Functions



## Features

- 1490nm DFB LD
- Multi Data Rate: from 125M to 1.25Gbps, NRZ
- Single +3.3V Power Supply
- RoHS Compliant and Lead-free
- AC/AC Differential Electrical Interface
- Compliant with Multi-Source Agreement (MSA) Small Form Factor Pluggable (SFP)
- Compliant with SFF-8472 Digital Diagnostic Monitoring Interface
- Single LC Connector
- Compliance with specifications for IEEE-802.3z Gigabit Ethernet at 1.25 Gbps
- Compliance with ANSI specifications for Fibre Channel applications at 1.06 Gbps
- Eye Safety  
Designed to meet Laser Class 1 comply with EN60825-1

## Applications

- Gigabit Ethernet Links
- Fibre Channel Links at 1.06 Gbps
- High Speed Backplane Interconnects
- Switched Backbones

## Description

The CT-1250TBP-CB8L-D 49/57 from Coretek Opto Corp. is the high performance and cost-effective module for serial optical data communication applications specified for single mode of multi-rate from 125M to 1.25 Gb/s. It operates with +3.3V power supply. The module is intended for single mode fiber, operates at a nominal wavelength of Tx: 1490nm / Rx: 1570nm and complies with Multi-Source Agreement (MSA) Small Form Factor Pluggable (SFP). Each module is integrated digital diagnostics functions via an I<sup>2</sup>C serial interface.

The module is a single fiber connector transceiver designed for use in Gigabit Ethernet applications and to provide IEEE-802.3z compliant link for 1.25Gb/s long reach applications. The characteristics are performed in accordance with Telcordia Specification GR-468-CORE.

## EMC

Most equipment utilizing high-speed transceivers will be required to meet the following requirements:

- 1) FCC in the United States
- 2) CENELEC EN55022 (CISPR 22) in Europe

To assist the customer in managing the overall equipment EMC performance, the transceivers have been designed to satisfy FCC class B limits and provide good immunity to radio-frequency electromagnetic fields.

## Eye Safety

The transceivers have been designed to meet Class 1 eye safety and comply with EN 60825-1.

# 1.25 Gigabit Ethernet-Single Mode Transceiver



## Product Information

Model Number	Operating Voltage & SD Output	Distance	Wavelength	Output Power	Sensitivity
CT-1250TBP-CB8L-D 49/57	3.3V TTL AC/AC	80 km	1490 nm DFB / 1570 nm	-1 ~ +4 dBm	≤ -25 dBm

## ABSOLUTE MAX RATINGS

PARAMETER	SYMBOL	MIN	MAX	UNIT	NOTE
Storage Temperature	T <sub>s</sub>	-40	85	°C	
Supply Voltage	V <sub>CC</sub>	0	6	V	
Data Input Voltage	---	0	V <sub>CC</sub>	V	
Supply Current	I <sub>s</sub>		300	mA	

## OPERATING CONDITIONS

PARAMETER	SYMBOL	MIN.	TYP.	MAX.	UNIT	NOTE
Case Operating Temperature	T <sub>A</sub>	0		70	°C	
Supply Voltage	V <sub>CC</sub>	3.1		3.5	V	
Data Input Voltage Swing	V <sub>ID</sub>	300		1860	mV	

## ELECTRICAL CHARACTERISTICS

PARAMETER	SYMBOL	MIN	MAX	UNIT	NOTE
<b>Transmitter</b>					
Transmitter Supply Current	I <sub>CCT</sub>		200	mA	
Tx_ Disable Input Voltage - Low	V <sub>IL</sub>	0	0.8	V	
Tx_ Disable Input Voltage - High	V <sub>IH</sub>	2.0	V <sub>CC</sub>	V	
Tx_ Fault Output Voltage - Low	V <sub>OL</sub>	0	0.8	V	
Tx_ Fault Output Voltage - High	V <sub>OH</sub>	2.0	V <sub>CC</sub>	V	
<b>Receiver</b>					
Receiver Supply Current	I <sub>CCR</sub>		100	mA	
Receiver Data Output Differential Voltage	V <sub>OD</sub>	0.4	1.3	V	
Rx_LOS Output Voltage - Low	V <sub>OL</sub>	0	0.8	V	
Rx_LOS Output Voltage - High	V <sub>OH</sub>	2.0	V <sub>CC</sub>	V	
MOD_DEF (1) , MOD_DEF (2) - Low	V <sub>IL</sub>	-0.6	V <sub>CC</sub> × 0.3	V	
MOD_DEF (1) , MOD_DEF (2) - High	V <sub>IH</sub>	V <sub>CC</sub> × 0.7	V <sub>CC</sub> + 0.5	V	

## TRANSMITTER ELECTRO-OPTICAL CHARACTERISTICS

PARAMETER	SYMBOL	MIN	TYP.	MAX	UNIT	NOTE
Optical Output Power	P <sub>o</sub>	-1		4	dBm	1
Extinction Ratio	ER	9			dB	
Center Wavelength	λ <sub>c</sub>	1470	1490	1510	nm	
Spectral Width (-20dB)	Δλ			1	nm	
Side Mode Suppression Ratio	SMSR	30			dB	
RIN	RIN			-120	dB/Hz	
Optical Rise time (20%-80% )	t <sub>r</sub>			260	ps	2
Optical Fall time (20%-80% )	t <sub>f</sub>			260	ps	2
Output Eye		Compliant with IEEE802.3z/D5.0				

# 1.25 Gigabit Ethernet-Single Mode Transceiver



## RECEIVER ELECTRO-OPTICAL CHARACTERISTICS

PARAMETER	SYMBOL	MIN	TYP.	MAX	UNIT	NOTE
Maximum Input Optical Power	$P_{max}$	-3			dBm	3
	1.25Gb/s			-25		3
	1.06Gb/s			-25		3
Minimum Input Optical Power	$P_{min}$			-25	dBm	4
	622Mb/s			-25		4
	155Mb/s			-25		4
	125Mb/s			-25		3
Operating Wavelength	$\lambda$	1550	1570	1590	nm	
Optical Return Loss	ORL	14			dB	
Receiver Electrical 3dB Upper Cutoff Frequency	---			1500	MHz	
LOS of Signal - Asserted	$P_A$	-35			dBm	
LOS of Signal - Deasserted	$P_D$			-24	dBm	
Loss of Signal -Hysterisis	$P_D - P_A$	0.5			dB	

### Notes:

1. Measured average power coupled into 9/125  $\mu$  m single mode fiber.
2. These are 20-80% values.
3. Measured with  $2^7-1$  PRBS at  $BER < 10^{-12}$
4. Measured with  $2^{23}-1$  PRBS at  $BER < 10^{-10}$

## TIMING CHARACTERISTICS

PARAMETER	SYMBOL	MIN	TYP.	MAX	UNIT	NOTE
TX_DISABLE Assert Time	$t_{off}$			10	$\mu$ s	
TX_DISABLE Negate Time	$t_{on}$			1	ms	
Time to initialize, include reset of TX_FAULT	$t_{init}$			300	ms	
TX_FAULT from fault to assertion	$t_{fault}$			100	$\mu$ s	
TX_DISABLE time to start reset	$t_{reset}$	10			$\mu$ s	
Receiver Loss of Signal Assert Time (off to on)	$t_{A,RX\_LOS}$			100	$\mu$ s	
Receiver Loss of Signal Assert Time (on to off)	$t_{D,RX\_LOS}$			100	$\mu$ s	

## BLOCK DIAGRAM OF TRANSCEIVER

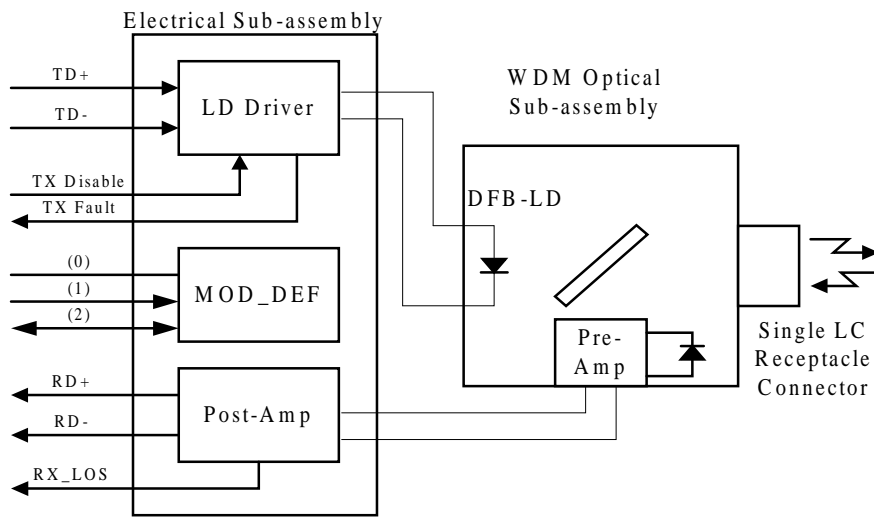

# 1.25 Gigabit Ethernet-Single Mode Transceiver



## PIN OUT DIAGRAM OF TRANSCEIVER

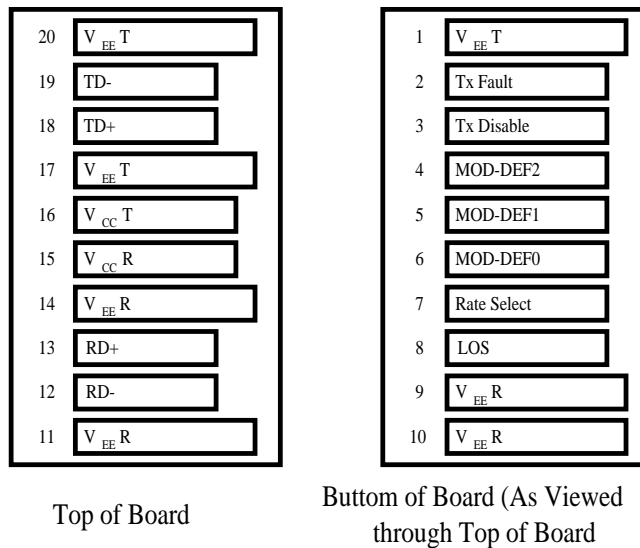

## PIN OUT TABLE

Pin	Symbol	Functional Description
1	VeeT	Transmitter Ground
2	TX Fault	Transmitter Fault Indication
3	TX Disable	Transmitter Disable – Module disables on high or open
4	MOD-DEF(2)	Module Definition 2 – Two wire serial ID interface
5	MOD-DEF(1)	Module Definition 1 – Two wire serial ID interface
6	MOD-DEF(0)	Module Definition 0 – Grounded in module
7	Rate Select	Not Connected
8	LOS	Loss of Signal
9	VeeR	Receiver Ground
10	VeeR	Receiver Ground
11	VeeR	Receiver Ground
12	RD-	Inverse Received Data Out
13	RD+	Received Data Out
14	VeeR	Receiver Ground
15	VccR	Receiver Power
16	VccT	Transmitter Power
17	VeeT	Transmitter Ground
18	TD+	Transmitter Data In
19	TD-	Inverse Transmitter Data In
20	VeeT	Transmitter Ground

# 1.25 Gigabit Ethernet-Single Mode Transceiver



## RECOMMENDED CIRCUIT SCHEMATIC

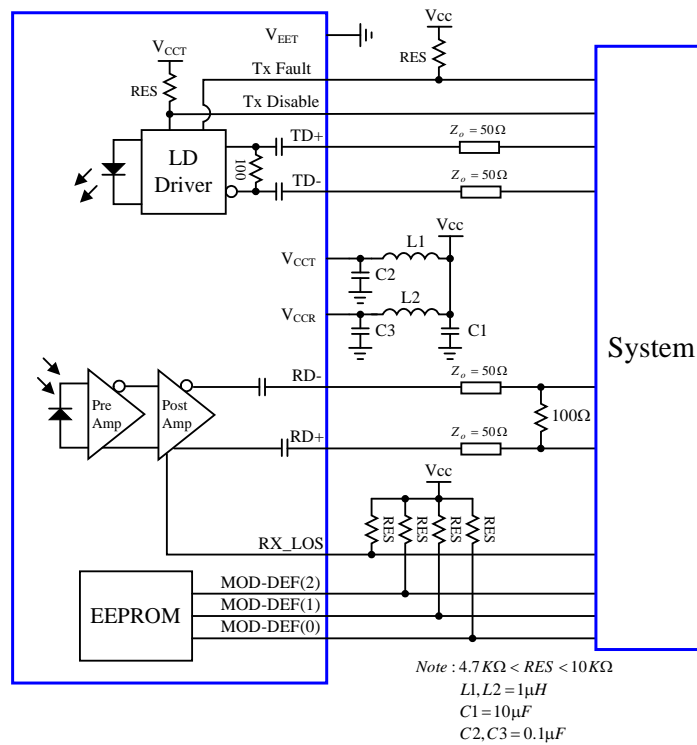

## MECHANICAL DIMENSIONS

Units in mm

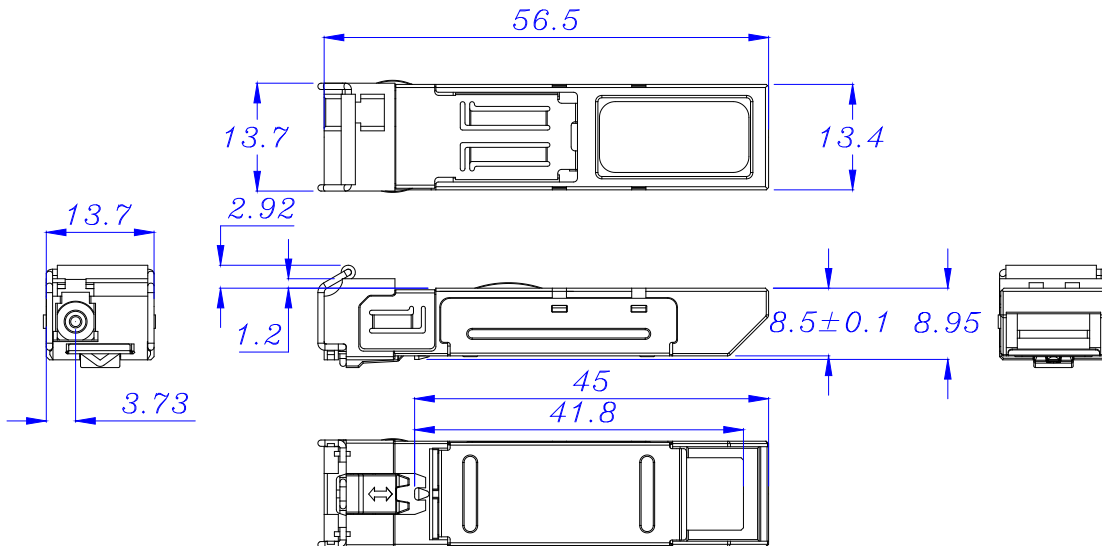

All dimensions are  $\pm 0.2\text{mm}$  unless otherwise specified.

### Claim:

CORETEK Opto Corp. reserves the right to make changes in the specification described hereinafter without prior notice.