

1.25 Gigabit Ethernet-Single Mode Transceiver

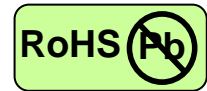

SFF BIDI, Single SC Connector, 1550nm DFB LD for Single Mode Fiber, RoHS Compliant



Features

- 1550nm DFB LD
- Data Rate: 1.25Gbps, NRZ
- Single +3.3V Power Supply
- RoHS Compliant and Lead-free
- AC/AC Differential Electrical Interface
- Compliant with Multi-Source Agreement (MSA) Small Form Factor (SFF) 2x5 Footprint
- Single SC Connector
- Compliance with specifications for IEEE-802.3z Gigabit Ethernet at 1.25 Gbps
- Compliance with ANSI specifications for Fibre Channel applications at 1.06 Gbps
- Eye Safety
Designed to meet Laser Class 1 comply with EN60825-1

Applications

- Gigabit Ethernet links
- Fibre Channel links at 1.06 Gbps
- High speed backplane interconnects
- Switched backbones

Description

The CT-1250TBF-KB6C from Coretek Opto Corp. is a high performance and cost-effective module for serial optical data communication applications specified for single mode of 1.25 Gb/s. It operates with +3.3V power supply. The module is intended for single mode fiber, operates at a nominal wavelength of Tx: 1550nm / Rx: 1310nm and complies with Multi-Source Agreement (MSA) Small Form Factor (SFF) 2x5 footprint. Each module consists of a bi-directional optical subassembly that combines a transmitter with a receiver and an electrical subassembly. All of them are housed in a metal package and the combination produces a reliable component.

The module is a single fiber connector transceiver designed for use in Gigabit Ethernet applications and to provide IEEE-802.3z compliant link for 1.25Gb/s intermediate reach applications. The characteristics are performed in accordance with Telcordia Specification GR-468-CORE.

EMC

Most equipment utilizing high-speed transceivers will be required to meet the following requirements:

- 1) FCC in the United States
- 2) CENELEC EN55022 (CISPR 22) in Europe

To assist the customer in managing the overall equipment EMC performance, the transceivers have been designed to satisfy FCC class B limits and provide good immunity to radio-frequency electromagnetic fields.

Eye Safety

The transceivers have been designed to meet Class 1 eye safety and comply with EN 60825-1.

1.25 Gigabit Ethernet-Single Mode Transceiver



Product Information

Model Number	Operating Voltage & SD Output	Distance	LD Type & Wavelength	Output Power	Sensitivity
CT-1250TBF-KB6C	3.3V TTL AC/AC	40 km	1550 nm DFB	-3 ~ +2 dBm	≤-23 dBm

ABSOLUTE MAX RATINGS

PARAMETER	SYMBOL	MIN	MAX	UNIT	NOTE
Storage Temperature	T _S	-40	85	°C	
Supply Voltage	V _{CC}	0	6	V	
Lead Soldering Temperature/Time	T _{SOLD}		260	°C	10 sec on lead
Data Input Voltage	---	0	V _{CC}	V	

OPERATING CONDITIONS

PARAMETER	SYMBOL	MIN.	TYP.	MAX.	UNIT	NOTE
Ambient Operating Temperature	T _A	0		70	°C	
Supply Voltage	V _{CC}	3.1		3.5	V	
Data Input Voltage Swing	V _{ID}	400		1660	mV	

ELECTRICAL CHARACTERISTICS

PARAMETER	SYMBOL	MIN	MAX	UNIT	NOTE
Transmitter					
Transmitter Supply Current	I _{CCT}		200	mA	
TTL Transmit Disable Input Voltage - Low	V _{IL}		0.8	V	
TTL Transmit Disable Input Voltage - High	V _{IH}	V _{CC} -1.3	V _{CC}	V	
Receiver					
Receiver Supply Current	I _{CCR}		100	mA	
Receiver Data Output Differential Voltage	V _{OD}	0.4	1.3	V	
TTL Signal Detect Output Voltage – Low	V _{OL}		0.8	V	
TTL Signal Detect Output Voltage – High	V _{OH}	2.0		V	

TRANSMITTER ELECTRO-OPTICAL CHARACTERISTICS

PARAMETER	SYMBOL	MIN	TYP.	MAX	UNIT	NOTE
Optical Output Power	P _o	-3		2	dBm	1
Extinction Ratio	ER	9			dB	
Center Wavelength	λ _c	1520	1550	1580	nm	
Spectral Width (-20dB)	Δλ			1	nm	
Side Mode Suppression Ratio	SMSR	30			dB	
RIN	RIN			-120	dB/Hz	
Optical Rise time (20%-80%)	t _r			260	ps	2
Optical Fall time (20%-80%)	t _f			260	ps	2
Output Eye		Compliant with IEEE802.3z/D5.0				

1.25 Gigabit Ethernet-Single Mode Transceiver



RECEIVER ELECTRO-OPTICAL CHARACTERISTICS

PARAMETER	SYMBOL	MIN	TYP.	MAX	UNIT	NOTE
Maximum Input Optical Power	P_{max}	-3			dBm	3
Receiver Sensitivity	P_{min}			-23	dBm	3
Operating Wavelength	λ	1260		1360	nm	
Optical Return Loss	ORL	12			dB	
Receiver Electrical 3dB Upper Cutoff Frequency	---			1500	MHz	
Loss of Signal - Asserted	P_D			-22	dBm	4
Loss of Signal - Deasserted	P_A	-35			dBm	5

Notes:

1. Measured average power coupled into 9/125 μ m single-mode fiber.
2. These are 20-80% values.
3. Measured with 2^7-1 PRBS at $BER < 10^{-12}$
4. Measured on transition – low to high
5. Measured on transition – high to low

BLOCK DIAGRAM OF TRANSCEIVER

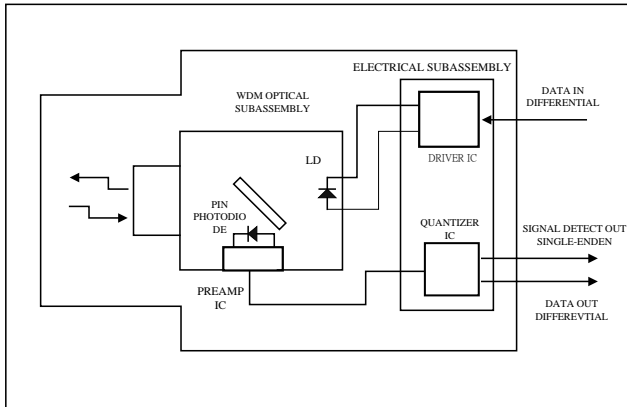

PIN OUT DIAGRAM OF TRANSCEIVER



PIN OUT TABLE

Pin	Symbol	Functional Description
Mounting Posts		
The mounting posts are provided for transceiver mechanical attachment to the circuit board. They should not be connected to the circuit ground but can be connected to the chassis ground.		
1	V_{EER}	Receiver Signal Ground
2	V_{CCR}	Receiver Power Supply
3	SD	Signal Detect is a TTL output. A high level indicates a received optical signal
4	RD-	Receiver Data Inverted Differential Output
5	RD+	Receiver Data Non-inverted Differential Output
6	V_{CCT}	Transmitter Power Supply
7	V_{EET}	Transmitter Signal Ground
8	TX_{DIS}	Transmitter Disable
9	TD+	Transmitter Data Non-inverted Differential Input
10	TD-	Transmitter Data Inverted Differential Input

1.25 Gigabit Ethernet-Single Mode Transceiver



RECOMMENDED CIRCUIT SCHEMATIC

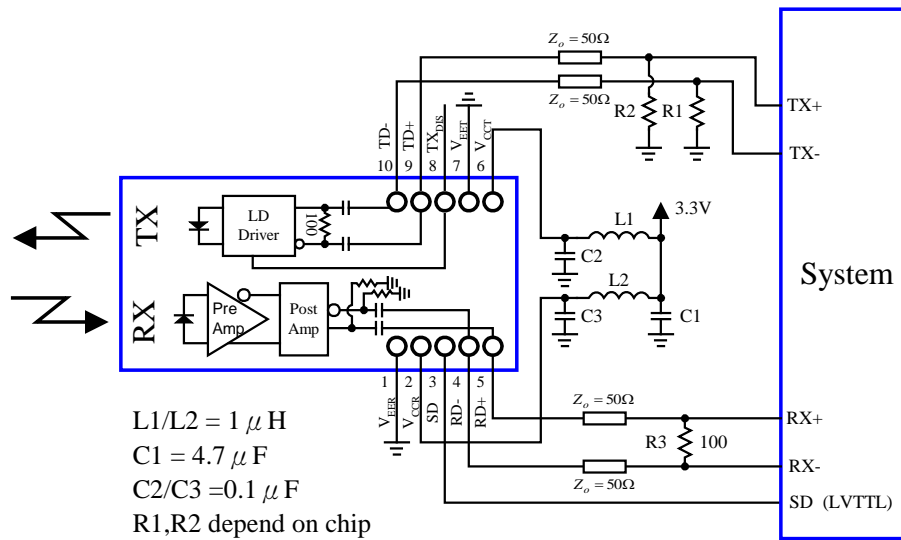

MECHANICAL DIMENSIONS

Units in mm

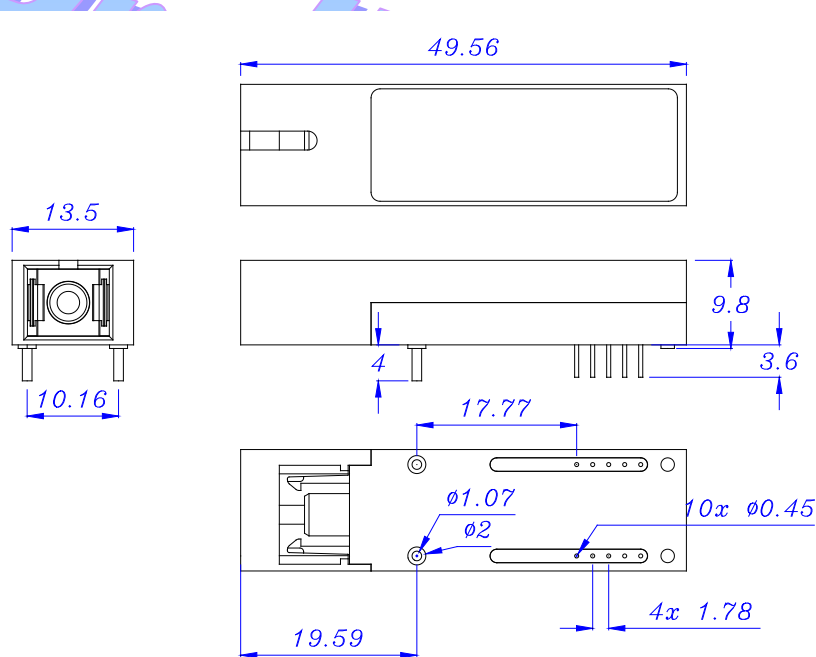

All dimensions are ± 0.2 mm unless otherwise specified.

1.25 Gigabit Ethernet-Single Mode Transceiver



RECOMMENDED SFF HOST BOARD LAYOUT

Units in mm

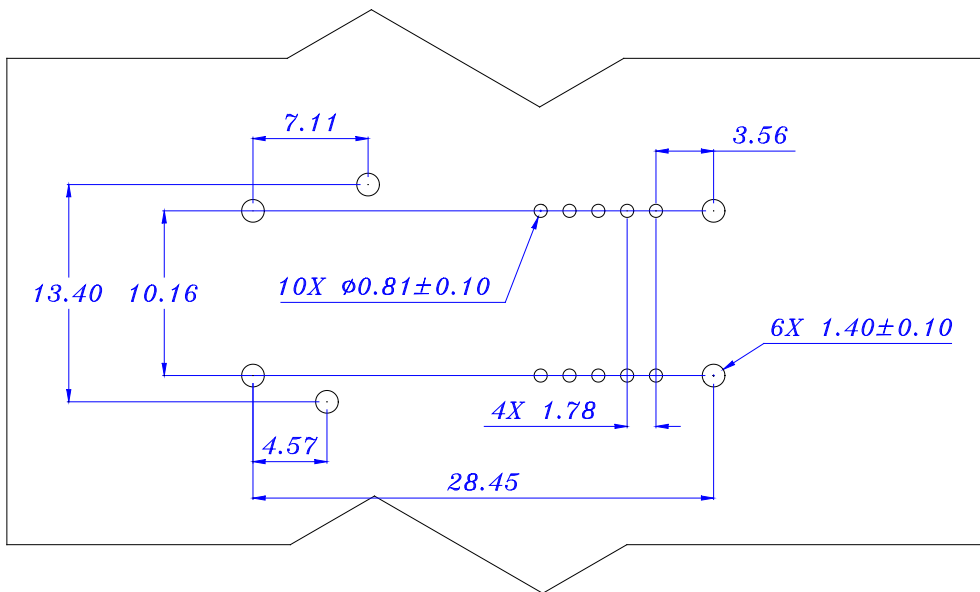

Claim:

CORETEK Opto Corp. reserves the right to make changes in the specification described hereinafter without prior notice.

Preliminary