

1.25 Gigabit Ethernet-Multimode Transceiver

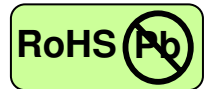

2x5 SFF, Duplex LC Connector, 850nm VCSEL for Multimode Fiber, RoHS Compliant



Features

- 850nm VCSEL
- Data Rate: 1.25Gbps, NRZ
- Single +3.3V Power Supply
- RoHS Compliant and Lead-free
- AC/AC Differential Electrical Interface
- Compliant with Multi-Source Agreement (MSA) Small Form Factor (SFF) 2x5 Footprint
- Duplex LC Connector
- Compliance with specifications for IEEE-802.3z Gigabit Ethernet (1000Base-SX) at 1.25 Gbps
- Compliance with ANSI specifications for Fibre Channel applications at 1.06 Gbps
- Eye Safety
Designed to meet Laser Class 1 comply with EN60825-1

Applications

- Gigabit Ethernet links
- Fibre Channel links at 1.06 Gbps
- High speed backplane interconnects
- Switched backbones

Description

The CT-1250NSR-SB1L from Coretek Opto Corp. is a high performance and cost-effective module for serial optical data communication applications specified for multimode of 1.25 Gb/s. It operates with +3.3V power supply. The module is intended for multimode fiber, operates at a nominal wavelength of 850nm and complies with Multi-Source Agreement (MSA) Small Form Factor (SFF) 2x5 footprint. Each module consists of a transmitter optical subassembly, a receiver optical subassembly and an electrical subassembly. All of them are housed in a plastic package and the combination produces a reliable component.

The module is a dual fiber connector transceiver designed for use in Gigabit Ethernet applications and to provide IEEE-802.3z compliant link for 1.25Gb/s short reach applications. The characteristics are performed in accordance with Telcordia Specification GR-468-CORE.

EMC

Most equipment utilizing high-speed transceivers will be required to meet the following requirements:

- 1) FCC in the United States
- 2) CENELEC EN55022 (CISPR 22) in Europe

To assist the customer in managing the overall equipment EMC performance, the transceivers have been designed to satisfy FCC class B limits and provide good immunity to radio-frequency electromagnetic fields.

Eye Safety

The transceivers have been designed to meet Class 1 eye safety and comply with EN 60825-1.

1.25 Gigabit Ethernet-Multimode Transceiver



Product Information

Model Number	Operating Voltage & SD Output	Wavelength	Output Power	Sensitivity	Distance
CT-1250NSR-SB1L	3.3V TTL AC/AC	850 nm	-9.5 ~ -4 dBm	≤ -17 dBm	$\frac{550 \text{ m}(50/125 \mu\text{m})}{275 \text{ m}(62.5/125 \mu\text{m})}$

ABSOLUTE MAX RATINGS

PARAMETER	SYMBOL	MIN	MAX	UNIT	NOTE
Storage Temperature	T_S	-40	85	$^{\circ}\text{C}$	
Supply Voltage	V_{CC}	0	6	V	
Lead Soldering Temperature/Time	T_{SOLD}		260	$^{\circ}\text{C}$	10 sec on lead
Data Input Voltage	---	0	V_{CC}	V	

OPERATING CONDITIONS

PARAMETER	SYMBOL	MIN.	TYP.	MAX.	UNIT	NOTE
Ambient Operating Temperature	T_A	0		70	$^{\circ}\text{C}$	
Supply Voltage	V_{CC}	3.1		3.5	V	
Data Input Voltage Swing	V_{ID}	400		1660	mV	

ELECTRICAL CHARACTERISTICS

PARAMETER	SYMBOL	MIN	MAX	UNIT	NOTE
Transmitter					
Transmitter Supply Current	I_{CCT}		140	mA	
TTL Transmit Disable Input Voltage - Low	V_{IL}		0.8	V	
TTL Transmit Disable Input Voltage - High	V_{IH}	$V_{CC}-1.3$	V_{CC}	V	
Receiver					
Receiver Supply Current	I_{CCR}		100	mA	
Receiver Data Output Differential Voltage	V_{OD}	0.4	1.3	V	
TTL Signal Detect Output Voltage - Low	V_{OL}		0.8	V	
TTL Signal Detect Output Voltage - High	V_{OH}	2.0		V	

TRANSMITTER ELECTRO-OPTICAL CHARACTERISTICS

PARAMETER	SYMBOL	MIN	TYP.	MAX	UNIT	NOTE
Optical Output Power	P_o	-9.5		-4	dBm	1
Extinction Ratio	ER	9			dB	
Center Wavelength	λ_c	830	850	860	nm	
Spectral Width (RMS)	$\Delta \lambda$			0.85	nm	
RIN	RIN			-117	dB/Hz	
Coupled Power Ratio	CPR	9			dB	2
Optical Rise time (20%-80%)	t_r			260	ps	3
Optical Fall time (20%-80%)	t_f			260	ps	3
Output Eye		Compliant with IEEE802.3z/D5.0				

1.25 Gigabit Ethernet-Multimode Transceiver



RECEIVER ELECTRO-OPTICAL CHARACTERISTICS

PARAMETER	SYMBOL	MIN	TYP.	MAX	UNIT	NOTE
Maximum Input Optical Power	P_{max}	-3			dBm	4
Receiver Sensitivity	P_{min}			-17	dBm	4
Operating Wavelength	λ	770		860	nm	
Optical Return Loss	ORL	12			dB	
Receiver Electrical 3dB Upper Cutoff Frequency	---			1500	MHz	
Loss of Signal - Asserted	P_D			-17	dBm	5
Loss of Signal - Deasserted	P_A	-30			dBm	6

Notes:

1. Measured average power coupled into 62.5/125 μ m, 0.275 NA or 50/125 μ m, 0.2 NA graded index multimode fiber.
2. CPR is measured in accordance with EIA/TIA-526-14A as referenced in IEEE 802.3 section 38.6.10.
3. These are 20-80% values.
4. Measured with 2^7-1 PRBS at $BER < 10^{-12}$
5. Measured on transition – low to high
6. Measured on transition – high to low

BLOCK DIAGRAM OF TRANSCEIVER

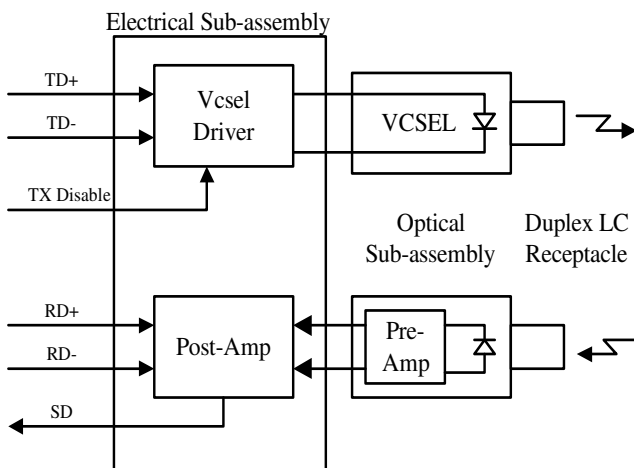

PIN OUT DIAGRAM OF TRANSCEIVER

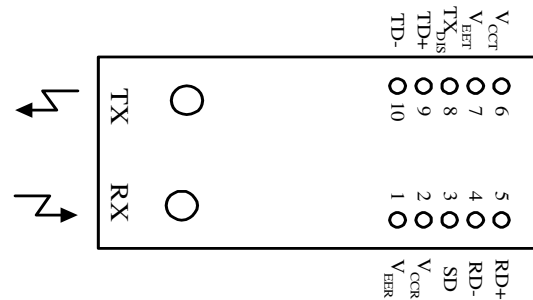

PIN OUT TABLE

Pin	Symbol	Functional Description
Mounting Posts		
The mounting posts are provided for transceiver mechanical attachment to the circuit board. They should not be connected to the circuit ground but can be connected to the chassis ground.		
1	V_{EER}	Receiver Signal Ground
2	V_{CCR}	Receiver Power Supply
3	SD	Signal Detect is a TTL output. A high level indicates a received optical signal
4	RD-	Receiver Data Inverted Differential Output
5	RD+	Receiver Data Non-inverted Differential Output
6	V_{CCT}	Transmitter Power Supply
7	V_{EET}	Transmitter Signal Ground
8	TX_{DIS}	Transmitter Disable
9	TD+	Transmitter Data Non-inverted Differential Input
10	TD-	Transmitter Data Inverted Differential Input

1.25 Gigabit Ethernet-Multimode Transceiver



RECOMMENDED CIRCUIT SCHEMATIC

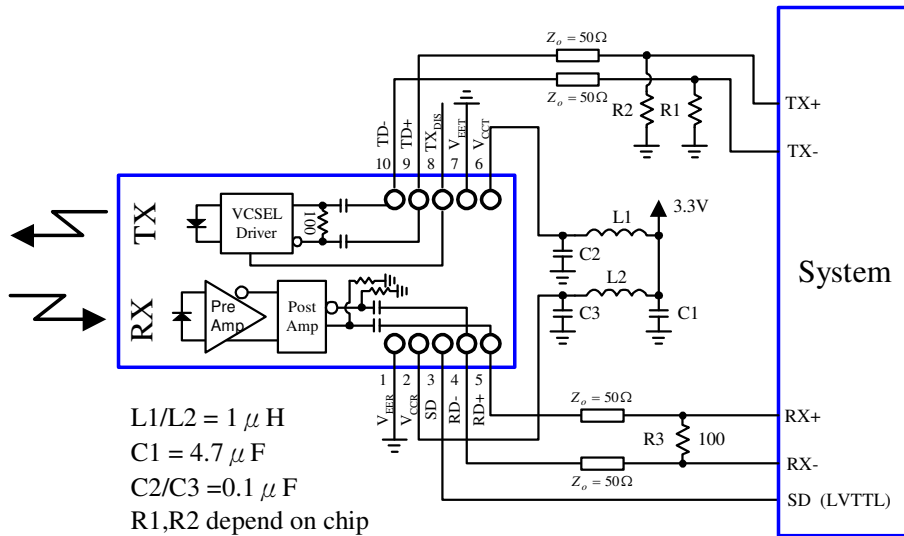

MECHANICAL DIMENSIONS

Units in mm

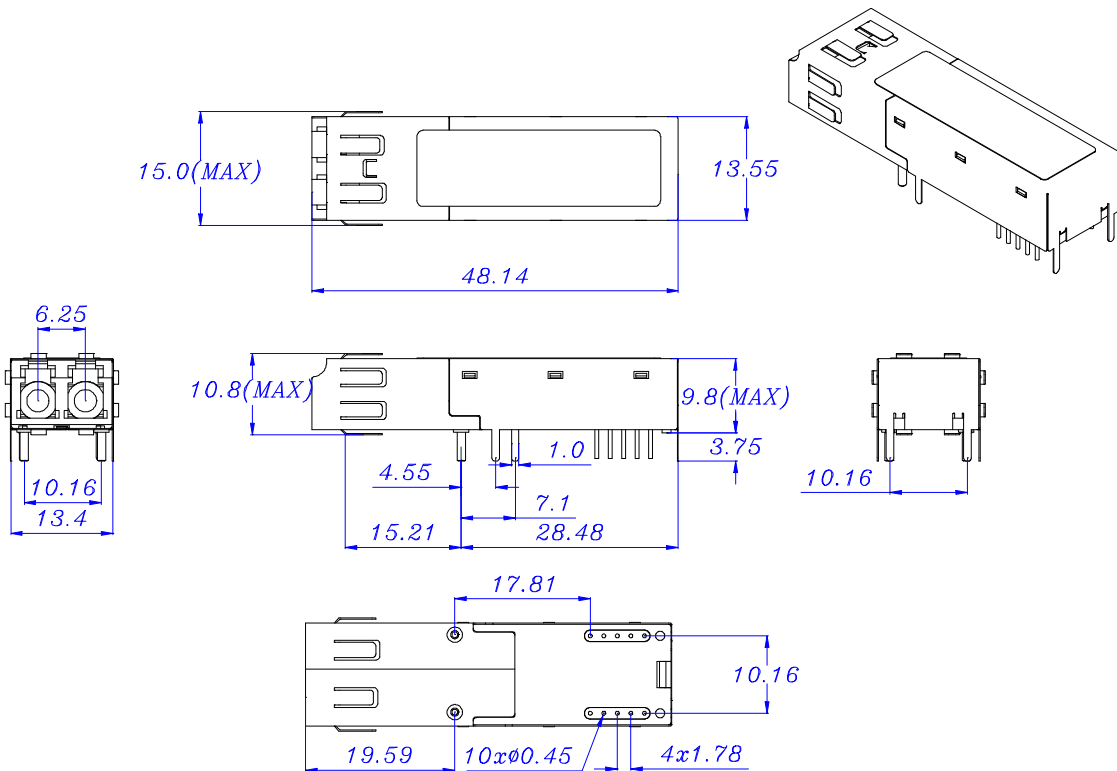

All dimensions are $\pm 0.2\text{mm}$ unless otherwise specified.

1.25 Gigabit Ethernet-Multimode Transceiver



RECOMMENDED SFF HOST BOARD LAYOUT

Units in mm

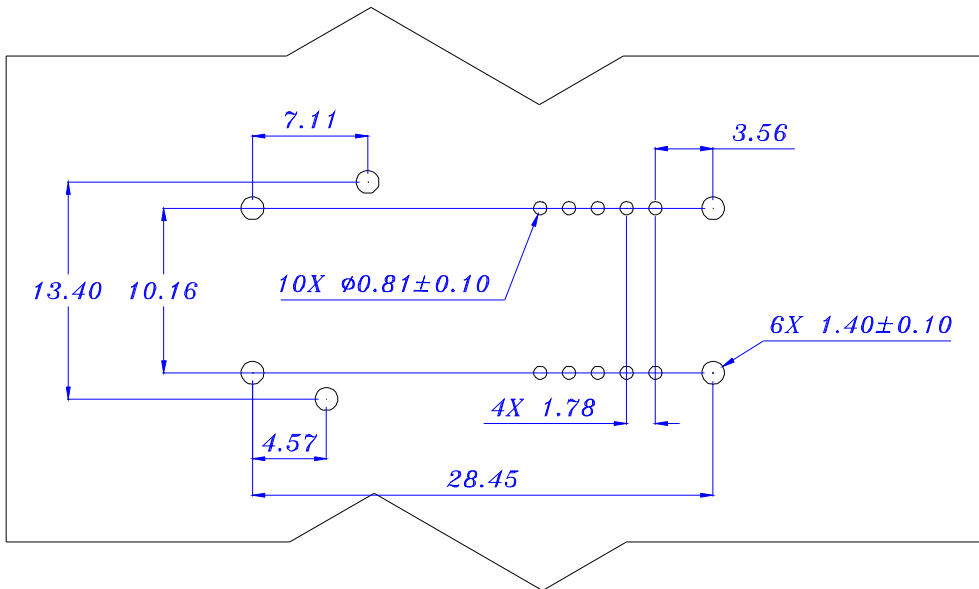

Claim:

CORETEK Opto Corp. reserves the right to make changes in the specification described hereinafter without prior notice.