

# 1.25 Gigabit Ethernet – Copper Transceiver

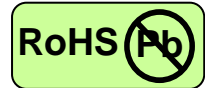

## SFP, RJ-45 Connector, Used for Twisted Pair Category 5 Cable, RoHS Compliant

Extended Operating Temperature from  $-40$  to  $+85^{\circ}\text{C}$



### Features

- Data Rate: 1.25 Gb/s
- Single +3.3 V Power Supply
- RoHS Compliant and Lead-free
- Compliant with Multi-Source Agreement (MSA) Small Form Factor Pluggable (SFP)
- Compact RJ-45 Connector
- 1000BASE-T Operation in Host Systems with SGMII Interface
- Compliance with specifications for IEEE-802.3-2002
- Compliance with FCC 47 CFR Part 15, Class B

### Applications

- Gigabit Ethernet Links over Category 5 Cable
- Switch/Router to Switch/Router
- High Speed I/O for File Servers

### Description

The CT-1250CSP-SB1R-A from Coretek Opto Corp. is the high performance and cost-effective module for serial data communication applications specified for data rates of 1.25 Gb/s. It operates with +3.3 V power supply. The module is intended for twisted-pair category 5 cable and complies with Multi-Source Agreement (MSA) Small Form Factor Pluggable (SFP). Each module is fully metallic enclosure for low EMI.

The module is a RJ-45 connector transceiver designed for use in Gigabit Ethernet 1000BASE-T applications and to provide IEEE-802.3-2002 compliant link for 1000 Mb/s up to 100 meters reach applications. The module supports 1000 Mb/s full duplex data-links with 5-level Pulse Amplitude Modulation (PAM) signals. All four pairs in the cable are used with symbol rate at 250 Mb/s on each pair.

The module provides standard serial ID information compliant with SFP MSA, which can be accessed with address of A0h via the 2-wire serial CMOS EEPROM protocol. The physical IC can also be accessed via 2-wire serial bus at address ACh. The address of the PHY is 1010110x, where x is the R/W bit.

### EMC

Most equipment utilizing high-speed transceivers will be required to meet the following requirements:

- 1) FCC in the United States

To assist the customer in managing the overall equipment EMC performance, the transceivers have been designed to satisfy FCC class B limits and provide good immunity to radio-frequency electromagnetic fields.

# 1.25 Gigabit Ethernet – Copper Transceiver



## Product Information

Model Number	Operating Voltage	Distance	Auto-negotiation Support	LOS Support
CT-1250CSP-SB1R-A	3.3V AC/AC	100 m	No	Yes

## ABSOLUTE MAX RATINGS

PARAMETER	SYMBOL	MIN	MAX	UNIT	NOTE
Storage Temperature	T <sub>S</sub>	-40	100	°C	
Supply Voltage	V <sub>CC</sub>	0	4	V	
Supply Current	I <sub>S</sub>		375	mA	1
Surge Current	I <sub>Sur</sub>		30	mA	

## OPERATING CONDITIONS

PARAMETER	SYMBOL	MIN.	TYP.	MAX.	UNIT	NOTE
Case Operating Temperature	T <sub>A</sub>	-40		85	°C	
Supply Voltage	V <sub>CC</sub>	3.135		3.465	V	
Data Input Voltage Swing	V <sub>ID</sub>	300		1860	mV	

## LOW SPEED ELECTRICAL CHARACTERISTICS

PARAMETER	SYMBOL	MIN	MAX	UNIT	NOTE
SFP Input Voltage - Low	V <sub>IL</sub>	0	0.8	V	2
SFP Input Voltage - High	V <sub>IH</sub>	2.0	V <sub>CC</sub> +0.3	V	2
SFP Output Voltage - Low	V <sub>OL</sub>	0	0.5	V	3
SFP Output Voltage - High	V <sub>OH</sub>	HostV <sub>CC</sub> -0.5	HostV <sub>CC</sub> +0.3	V	3
MOD_DEF (1) , MOD_DEF (2) - Low	V <sub>IL</sub>	-0.6	V <sub>CC</sub> x0.3	V	3
MOD_DEF (1) , MOD_DEF (2) - High	V <sub>IH</sub>	V <sub>CC</sub> x0.7	V <sub>CC</sub> +0.5	V	3

## HIGH SPEED ELECTRICAL CHARACTERISTICS

PARAMETER	SYMBOL	MIN	TYP.	MAX	UNIT	NOTE
Line Frequency	f <sub>L</sub>		125		MHz	4
TX Output Impedance (differential)	Z <sub>out_TX</sub>		100		Ohm	
RX Input Impedance (differential)	Z <sub>in_RX</sub>		100		Ohm	
Single Ended Data Input Swing	V <sub>in</sub>	250		1200	mV	
Single Ended Data Output Swing	V <sub>out</sub>	350		800	mV	
Rise time (20%-80% )	t <sub>r</sub>		175		ps	
Fall time (20%-80% )	t <sub>f</sub>		175		ps	
TX Input Impedance (single ended)	Z <sub>in_TX</sub>		50		Ohm	
RX Output Impedance (single ended)	Z <sub>out_RX</sub>		50		Ohm	

### Notes:

- 1.2W max power over full range of voltage and temperature
- 4.7k to 10k pull-up to V<sub>CC</sub>
- 4.7k to 10k pull-up to host V<sub>CC</sub>
- 5-level encoding, per IEEE 802.3
- Clock tolerance is +/- 50 ppm.
- By default, the module is a full duplex device in preferred master mode.
- Automatic crossover detection is enabled. External crossover cable is not required.
- 1000 BASE-T operation requires the host system to have an SGMII interface with no clocks. With a SERDES that does not support SGMII, the module will operate at 1000BASE-T only.

# 1.25 Gigabit Ethernet – Copper Transceiver



## PIN OUT DIAGRAM OF TRANSCEIVER

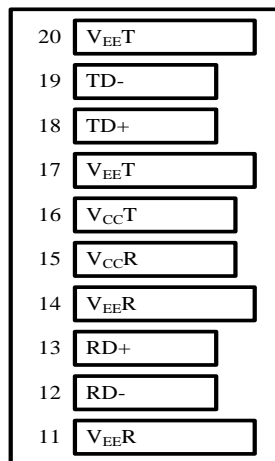

Top of Board

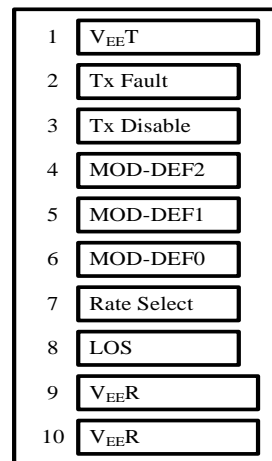

Bottom of Board (As Viewed through Top of Board)

## PIN OUT TABLE

Pin	Symbol	Functional Description
1	VeeT	Transmitter Ground (common with receiver ground)
2	TX Fault	Not Supported (grounded in module)
3	TX Disable	Transmitter Disable – Module disables on high or open
4	MOD-DEF(2)	Module Definition 2 – Two wire serial ID interface
5	MOD-DEF(1)	Module Definition 1 – Two wire serial ID interface
6	MOD-DEF(0)	Module Definition 0 – Grounded in module
7	Rate Select	Not Connected
8	LOS	Loss of Signal
9	VeeR	Receiver Ground (common with transmitter ground)
10	VeeR	Receiver Ground (common with transmitter ground)
11	VeeR	Receiver Ground (common with transmitter ground)
12	RD-	Inverse Received Data Out (AC coupled)
13	RD+	Received Data Out (AC coupled)
14	VeeR	Receiver Ground (common with transmitter ground)
15	VccR	Receiver Power
16	VccT	Transmitter Power
17	VeeT	Transmitter Ground (common with receiver ground)
18	TD+	Transmitter Data In (AC coupled)
19	TD-	Inverse Transmitter Data In (AC coupled)
20	VeeT	Transmitter Ground (common with receiver ground)

# 1.25 Gigabit Ethernet – Copper Transceiver



## EEPROM MEMORY CONTENTS (A0h)

Addr.	Hex	ASCII	Addr.	Hex	ASCII	Addr.	Hex	ASCII	Addr.	Hex	ASCII
0	03		32	20		64	00		96	00	
1	04		33	20		65	10		97	00	
2	00		34	20		66	00		98	00	
3	00		35	00		67	00		99	00	
4	00		36	00		68		SN#	100	00	
5	00		37	00		69		SN#	101	00	
6	08		38	00		70		SN#	102	00	
7	00		39	43	C	71		SN#	103	00	
8	00		40	54	T	72		SN#	104	00	
9	00		41	2D	-	73		SN#	105	00	
10	00		42	31	1	74		SN#	106	00	
11	01		43	32	2	75		SN#	107	00	
12	0D		44	35	5	76		SN#	108	00	
13	00		45	30	0	77		SN#	109	00	
14	00		46	43	C	78		SN#	110	00	
15	00		47	53	S	79		SN#	111	00	
16	00		48	50	P	80		SN#	112	00	
17	00		49	2D	-	81		SN#	113	00	
18	64		50	53	S	82		SN#	114	00	
19	00		51	42	B	83		SN#	115	00	
20	43	C	52	31	1	84		Date#	116	00	
21	4F	O	53	52	R	85		Date#	117	00	
22	52	R	54	41	A	86		Date#	118	00	
23	45	E	55	20		87		Date#	119	00	
24	54	T	56	31	1	88		Date#	120	00	
25	45	E	57	30	0	89		Date#	121	00	
26	4B	K	58	20		90	20		122	00	
27	20		59	20		91	20		123	00	
28	20		60	00		92	00		124	00	
29	20		61	00		93	00		125	00	
30	20		62	00		94	00		126	00	
31	20		63		Check sum	95		Check sum	127	00	

# 1.25 Gigabit Ethernet – Copper Transceiver



## RECOMMENDED CIRCUIT SCHEMATIC

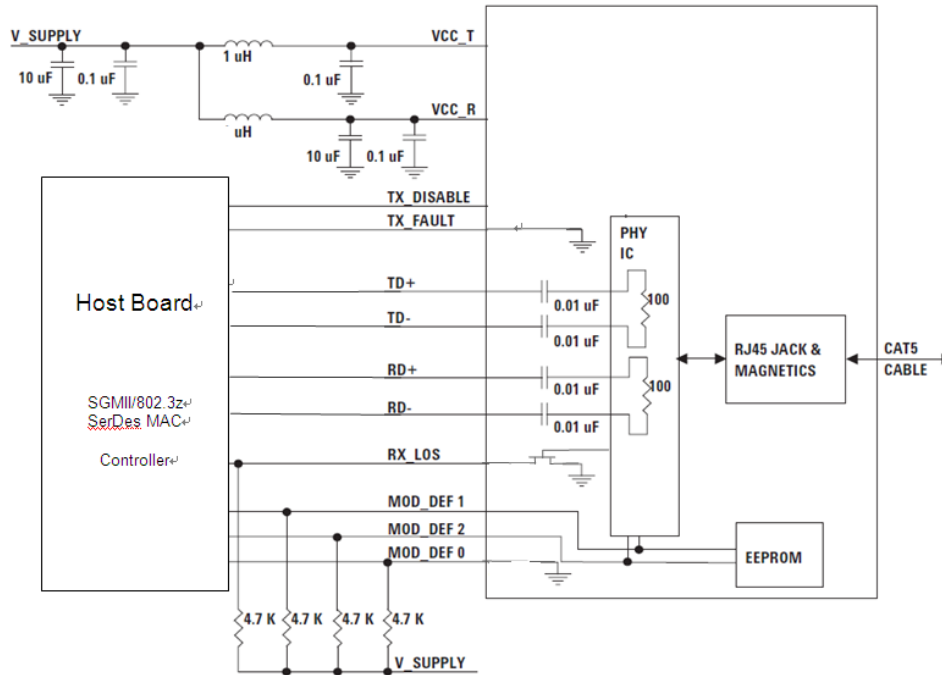

## MECHANICAL DIMENSIONS

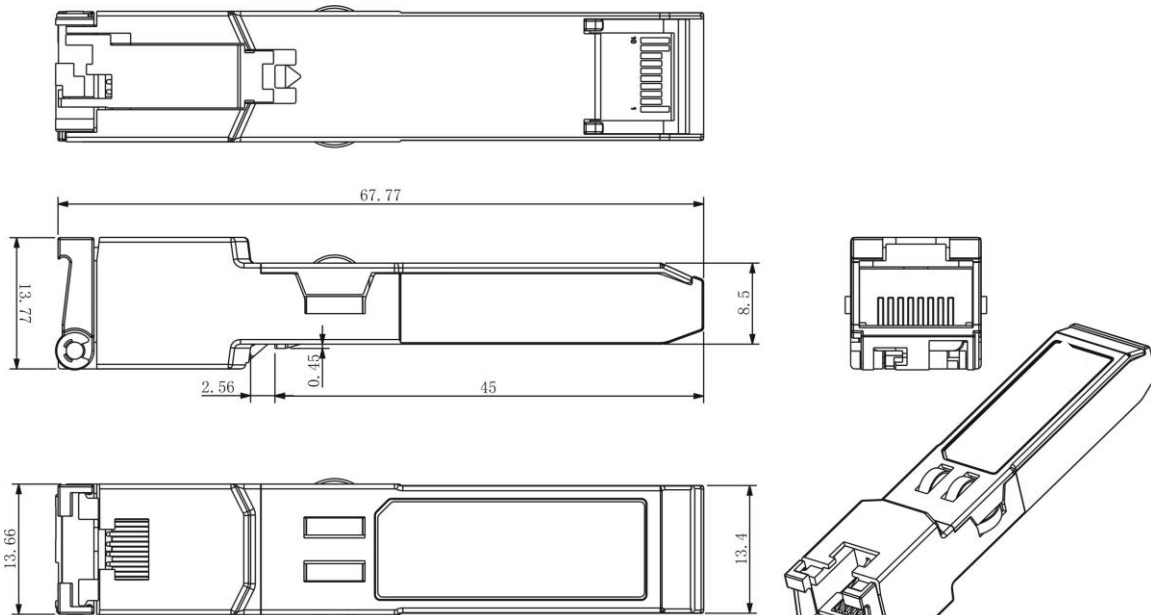

COPPER SFP Transceiver  
(Unit: mm View:

All dimensions are  $\pm 0.2\text{mm}$  unless otherwise specified.

### Claim:

CORETEK Opto Corp. reserves the right to make changes in the specification described hereinafter without prior notice.