

# 622Mbps ATM-Single Mode Transceiver

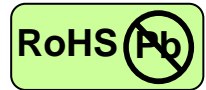

SFP, Duplex LC Connector, 1550nm DFB LD for Single Mode Fiber, RoHS Compliant  
Digital Diagnostics Functions, Extended Operating Temperature from -40 to +85 °C



## Features

- 1550nm DFB LD
- APD Receiver
- Data Rate: 622Mbps, NRZ
- Single +3.3V Power Supply
- RoHS Compliant and Lead-free
- AC/AC Differential Electrical Interface
- Compliant with Multi-Source Agreement (MSA) Small Form Factor Pluggable (SFP)
- Compliant with SFF-8472 Digital Diagnostic Monitoring Interface
- Duplex LC Connector
- Compliance with ATM Standard
- Eye Safety  
Designed to meet Laser Class 1 comply with EN60825-1

## Applications

- ATM/SONET OC-12/SDH STM-4
- Single mode fiber links
- Optical-Electrical Interface Conversion

## Description

The CT-0622TSP-KBAL-E from Coretek Opto Corp. is the high performance and cost-effective module for serial optical data communication applications specified for single mode of 622 Mb/s. It operates with +3.3V power supply. The module is intended for single mode fiber, operates at a nominal wavelength of 1550nm and complies with Multi-Source Agreement (MSA) Small Form Factor Pluggable (SFP). Each module is integrated digital diagnostics functions via an I<sup>2</sup>C serial interface.

The module is a duplex LC connector transceiver designed to provide an ATM/SONET OC-12/SDH STM-4 compliant link for 622 Mb/s long reach applications. The characteristics are performed in accordance with Telcordia Specification GR-468-CORE.

## EMC

Most equipment utilizing high-speed transceivers will be required to meet the following requirements:

- 1) FCC in the United States
- 2) CENELEC EN55022 (CISPR 22) in Europe

To assist the customer in managing the overall equipment EMC performance, the transceivers have been designed to satisfy FCC class B limits and provide good immunity to radio-frequency electromagnetic fields.

## Eye Safety

The transceivers have been designed to meet Class 1 eye safety and comply with EN 60825-1.

# 622Mbps ATM-Single Mode Transceiver



## Product Information

Model Number	Operating Voltage & SD Output	Distance	LD Type & Wavelength	Output Power	Sensitivity
CT-0622TSP-KBAL-E	3.3V TTL AC/AC	120 km	1550 nm DFB	0 ~ +5 dBm	≤-34 dBm

## ABSOLUTE MAX RATINGS

PARAMETER	SYMBOL	MIN	MAX	UNIT	NOTE
Storage Temperature	T <sub>S</sub>	-40	85	°C	
Supply Voltage	V <sub>CC</sub>	0	6	V	
Data Input Voltage	---	0	V <sub>CC</sub>	V	

## OPERATING CONDITIONS

PARAMETER	SYMBOL	MIN.	TYP.	MAX.	UNIT	NOTE
Case Operating Temperature	T <sub>A</sub>	-40		85	°C	
Supply Voltage	V <sub>CC</sub>	3.1		3.5	V	
Data Input Voltage Swing	V <sub>ID</sub>	400		1660	mV	

## ELECTRICAL CHARACTERISTICS

PARAMETER	SYMBOL	MIN	MAX	UNIT	NOTE
<b>Transmitter</b>					
Transmitter Supply Current	I <sub>CC</sub> T		200	mA	
Tx_Disable Input Voltage - Low	V <sub>IL</sub>	0	0.8	V	
Tx_Disable Input Voltage - High	V <sub>IH</sub>	2.0	V <sub>CC</sub>	V	
Tx_Fault Output Voltage - Low	V <sub>OL</sub>	0	0.8	V	
Tx_Fault Output Voltage - High	V <sub>OH</sub>	2.0	V <sub>CC</sub>	V	
<b>Receiver</b>					
Receiver Supply Current	I <sub>CC</sub> R		100	mA	
Receiver Data Output Differential Voltage	V <sub>OD</sub>	0.4	1.3	V	
Rx_LOS Output Voltage - Low	V <sub>OL</sub>	0	0.8	V	
Rx_LOS Output Voltage - High	V <sub>OH</sub>	2.0	V <sub>CC</sub>	V	
MOD_DEF (1) , MOD_DEF (2) - Low	V <sub>IL</sub>	-0.6	V <sub>CC</sub> × 0.3	V	
MOD_DEF (1) , MOD_DEF (2) - High	V <sub>IH</sub>	V <sub>CC</sub> × 0.7	V <sub>CC</sub> + 0.5	V	

## TRANSMITTER ELECTRO-OPTICAL CHARACTERISTICS

PARAMETER	SYMBOL	MIN	TYP.	MAX	UNIT	NOTE
Optical Output Power	P <sub>O</sub>	0		5	dBm	1
Extinction Ratio	ER	10			dB	
Center Wavelength	λ <sub>c</sub>	1510	1550	1580	nm	
Spectral Width (-20dB)	Δλ			1	nm	
Side Mode Suppression Ratio	SMSR	30			dB	
Optical Rise time (20%-80%)	t <sub>r</sub>			1.2	ns	2
Optical Fall time (20%-80%)	t <sub>f</sub>			1.2	ns	2
Output Eye		Compliant with ITU recommendation G.957				

# 622Mbps ATM-Single Mode Transceiver



## RECEIVER ELECTRO-OPTICAL CHARACTERISTICS

PARAMETER	SYMBOL	MIN	TYP.	MAX	UNIT	NOTE
Maximum Input Optical Power	$P_{max}$	-8			dBm	3
Receiver Sensitivity	$P_{min}$			-34	dBm	3
Operating Wavelength	$\lambda$	1100		1600	nm	
Loss of Signal - Asserted	$P_A$	-42			dBm	
Loss of Signal - Deasserted	$P_D$			-34	dBm	
Loss of Signal -Hysterisis	$P_D - P_A$	0.5			dB	

### Notes:

1. Measured average power coupled into 9/125  $\mu$  m single mode fiber.
2. These are 20-80% values.
3. Measured with  $2^{23}-1$  PRBS at BER <  $10^{-10}$

## TIMING CHARACTERISTICS

PARAMETER	SYMBOL	MIN	TYP.	MAX	UNIT	NOTE
TX_DISABLE Assert Time	$t_{off}$			10	$\mu$ s	
TX_DISABLE Negate Time	$t_{on}$			1	ms	
Time to initialize, include reset of TX_FAULT	$t_{init}$			300	ms	
TX_FAULT from fault to assertion	$t_{fault}$			100	$\mu$ s	
TX_DISABLE time to start reset	$t_{reset}$	10			$\mu$ s	
Receiver Loss of Signal Assert Time (off to on)	$t_{A,RX\_LOS}$			100	$\mu$ s	
Receiver Loss of Signal Assert Time (on to off)	$t_{D,RX\_LOS}$			100	$\mu$ s	

## BLOCK DIAGRAM OF TRANSCEIVER

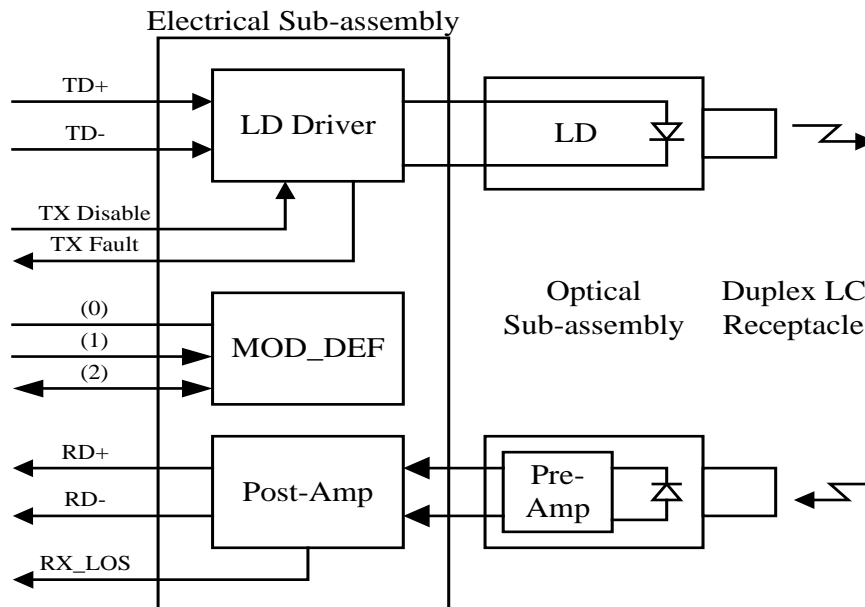

# 622Mbps ATM-Single Mode Transceiver



## PIN OUT DIAGRAM OF TRANSCEIVER

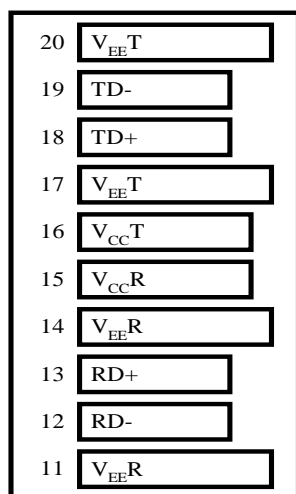

Top of Board

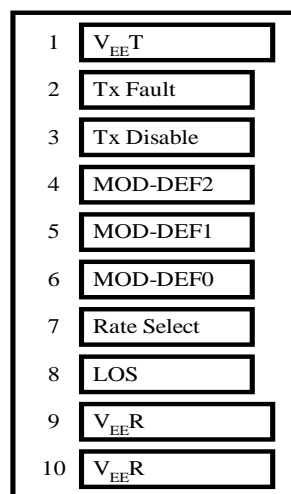

Bottom of Board (As Viewed through Top of Board)

## PIN OUT TABLE

Pin	Symbol	Functional Description
1	VeeT	Transmitter Ground
2	TX Fault	Transmitter Fault Indication
3	TX Disable	Transmitter Disable – Module disables on high or open
4	MOD-DEF(2)	Module Definition 2 – Two wire serial ID interface
5	MOD-DEF(1)	Module Definition 1 – Two wire serial ID interface
6	MOD-DEF(0)	Module Definition 0 – Grounded in module
7	Rate Select	Not Connected
8	LOS	Loss of Signal
9	VeeR	Receiver Ground
10	VeeR	Receiver Ground
11	VeeR	Receiver Ground
12	RD-	Inverse Received Data Out
13	RD+	Received Data Out
14	VeeR	Receiver Ground
15	VccR	Receiver Power
16	VccT	Transmitter Power
17	VeeT	Transmitter Ground
18	TD+	Transmitter Data In
19	TD-	Inverse Transmitter Data In
20	VeeT	Transmitter Ground

# 622Mbps ATM-Single Mode Transceiver



## EEPROM Serial ID Memory Contents

Table 1 - EEPROM Serial ID Memory Contents (A0h)

Addr.	Field Size (Bytes)	Name of Field	Hex	Description
00	1	Identifier	03	SFP
01	1	Ext. Identifier	04	MOD4
02	1	Connector	07	LC
03 ~ 10	8	Transceiver Codes	00 08 40 00 00 00 00 00	
11	1	Encoding	03	NRZ
12	1	BR,nominal	06	
13	1	Reserved	00	
14	1	Length (SMF)-km	78	120 Km
15	1	Length (SMF)-100m	FF	
16	1	Length (50um,OM2)	00	
17	1	Length (62.5um,OM1)	00	
18	1	Length (copper)	00	
19	1	Length (50um, OM3)	00	
20 ~ 35	16	Vendor Name	43 4F 52 45 54 45 4B 20 20 20 20 20 20 20 20 20	CORETEK
36	1	Unallocated	00	
37 ~ 39	3	OUI Code	00 00 00	
40 ~ 55	16	Vendor PN	43 54 2D 30 36 32 32 54 53 50 2D 4B 42 41 4C 45	CT-0622TSP-KBALE
56 ~ 59	4	Vendor Rev	30 30 30 30	0000
60 ~ 61	2	Wavelength	06 0E	1550 nm
62	1	Reserved	00	
63	1	CC BASE	XX	Check sum
64 ~ 65	2	Options	00 1A	LOS,TX_FAULT and TX_DISABLE
66	1	BR max	00	
67	1	BR min	00	
68 ~ 83	16	Vendor SN	BFxxxxxxxxxxxxxx	
84 ~ 91	8	Date code		
92	1	Diagnostic Monitoring Type	68	
93	1	Enhanced Options	90	

# 622Mbps ATM-Single Mode Transceiver



94	1	Unallocated	00	
95	1	CC BASE	XX	Check sum
96 ~ 127	32	Vendor Specific		

**Table 2- EEPROM Serial ID Memory Contents (A2h)**

Addr.	Field Size (Bytes)	Name of Field	Hex	Description
00 ~ 07	8	Temperature Alarm/Warning (°C)	6E 00 D8 00 64 00 DD 00	Alarm_H/L : 110/-40 Warning_H/L : 100/-35
08 ~ 15	8	Voltage Alarm/Warning (V)	8C A0 75 30 88 B8 79 18	Alarm_H/L : 3.6/3 Warning_H/L : 3.5/3.1
16 ~ 23	8	BiasCurrent Alarm/Warning (mA)	9C 40 03 E8 88 B8 07 D0	Alarm_H/L : 80/2 Warning_H/L : 70/4
24 ~ 31	8	Tx Power Alarm/Warning (dBm)	9B 83 1F 07 7B 87 27 10	Alarm_H/L : +6/-1 Warning_H/L : +5/0
32 ~ 39	8	Rx Power Alarm/Warning (dBm)	06 30 00 03 04 EA 00 05	Alarm_H/L : -8/-34 Warning_H/L : -9/-33
128 ~ 143	16	Vendor Specific		

## Monitoring Specification

The digital diagnostic monitoring interface also defines another 256-byte memory map in EEPROM, which makes use of the 8 bit address 1010001X(A2h). Please see Figure 1. For detail EEPROM information, please refer to the related document of SFF-8472 Rev 9.5. The monitoring specification of this product is described in Table3.

**Figure 3.1: Digital Diagnostic Memory Map**

### Specific Data Field Descriptions

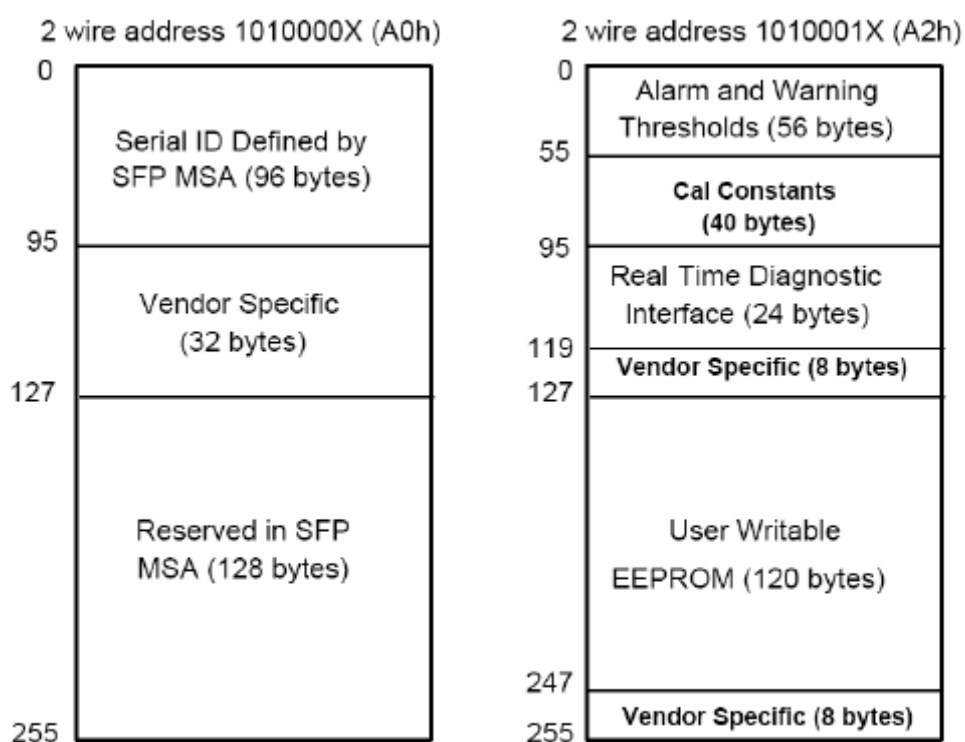

**Figure 1, EEPROM Memory Map Specific Data Field Descriptions**

**Table3 - Monitoring Specification**

Parameter	Range	Accuracy	Calibration
Temperature	-40°C to 85°C	±3°C	Internal
Voltage	3.0 to 3.6V	±3%	Internal
Bias Current	0 to 100mA	±10%	Internal
TX Power	0 to +5 dBm	±3dB	Internal
RX Power	-30 to -3 dBm	±3dB	Internal

# 622Mbps ATM-Single Mode Transceiver



## RECOMMENDED CIRCUIT SCHEMATIC

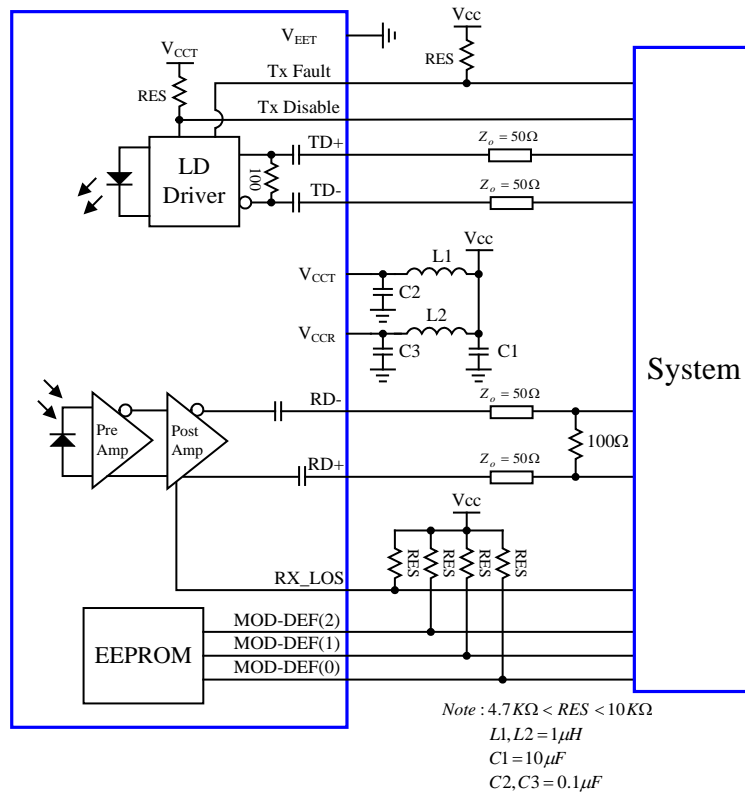

## MECHANICAL DIMENSIONS

Units in mm

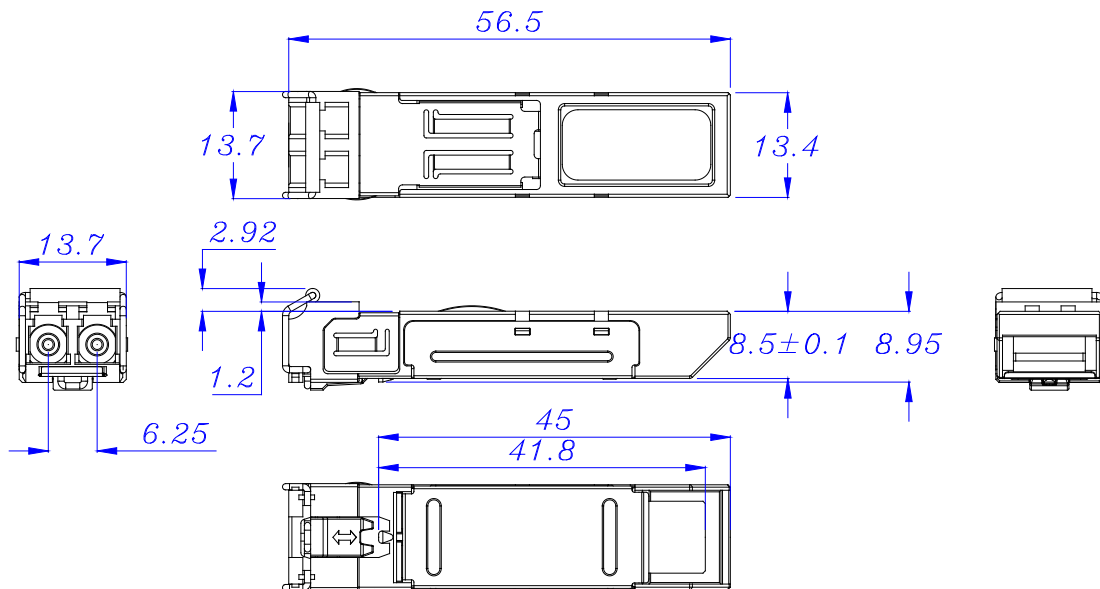

All dimensions are  $\pm 0.2\text{mm}$  unless otherwise specified.

### Claim:

CORETEK Opto Corp. reserves the right to make changes in the specification described hereinafter without prior notice.