

# 622Mbps ATM-Single Mode Transceiver

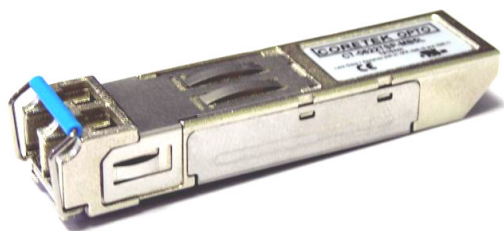

SFP, Duplex LC Connector, 1550nm DFB LD for Single Mode Fiber, RoHS Compliant

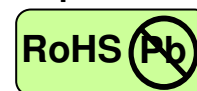

## Features

- 1550nm DFB LD
- Data Rate: 622Mbps, NRZ
- Single +3.3V Power Supply
- RoHS Compliant and Lead-free
- AC/AC Differential Electrical Interface
- Compliant with Multi-Source Agreement (MSA) Small Form Factor Pluggable (SFP)
- Duplex LC Connector
- Compliance with ATM Standard
- Eye Safety  
Designed to meet Laser Class 1 comply with EN60825-1

## Applications

- ATM/SONET OC-12/SDH STM-4
- Single mode fiber links
- Optical-Electrical Interface Conversion

## Description

The CT-0622TSP-KB8L from Coretek Opto Corp. is the high performance and cost-effective module for serial optical data communication applications specified for single mode of 622 Mb/s. It operates with +3.3V power supply. The module is intended for single mode fiber, operates at a nominal wavelength of 1550nm and complies with Multi-Source Agreement (MSA) Small Form Factor Pluggable (SFP). Each module consists of a transmitter optical subassembly, a receiver optical subassembly and an electrical subassembly. All of them are housed in a metal package and the combination produces a reliable component.

The module is a duplex LC connector transceiver designed to provide an ATM/SONET OC-12/SDH STM-4 compliant link for 622 Mb/s long reach applications. The characteristics are performed in accordance with Telcordia Specification GR-468-CORE.

## EMC

Most equipment utilizing high-speed transceivers will be required to meet the following requirements:

- 1) FCC in the United States
- 2) CENELEC EN55022 (CISPR 22) in Europe

To assist the customer in managing the overall equipment EMC performance, the transceivers have been designed to satisfy FCC class B limits and provide good immunity to radio-frequency electromagnetic fields.

## Eye Safety

The transceivers have been designed to meet Class 1 eye safety and comply with EN 60825-1.

# 622Mbps ATM-Single Mode Transceiver



## Product Information

Model Number	Operating Voltage & SD Output	Distance	LD Type & Wavelength	Output Power	Sensitivity
CT-0622TSP-KB8L	3.3V TTL AC/AC	80 km	1550 nm DFB	-3 ~ +2 dBm	$\leq -28$ dBm

## ABSOLUTE MAX RATINGS

PARAMETER	SYMBOL	MIN	MAX	UNIT	NOTE
Storage Temperature	$T_S$	-40	85	$^{\circ}\text{C}$	
Supply Voltage	$V_{CC}$	0	6	V	
Data Input Voltage	---	0	$V_{CC}$	V	

## OPERATING CONDITIONS

PARAMETER	SYMBOL	MIN.	TYP.	MAX.	UNIT	NOTE
Case Operating Temperature	$T_A$	0		70	$^{\circ}\text{C}$	
Supply Voltage	$V_{CC}$	3.1		3.5	V	
Data Input Voltage Swing	$V_{ID}$	400		1660	mV	

## ELECTRICAL CHARACTERISTICS

PARAMETER	SYMBOL	MIN	MAX	UNIT	NOTE
<b>Transmitter</b>					
Transmitter Supply Current	$I_{CCT}$		200	mA	
Tx_Disable Input Voltage - Low	$V_{IL}$	0	0.8	V	
Tx_Disable Input Voltage - High	$V_{IH}$	2.0	$V_{CC}$	V	
Tx_Fault Output Voltage - Low	$V_{OL}$	0	0.8	V	
Tx_Fault Output Voltage - High	$V_{OH}$	2.0	$V_{CC}$	V	
<b>Receiver</b>					
Receiver Supply Current	$I_{CCR}$		100	mA	
Receiver Data Output Differential Voltage	$V_{OD}$	0.4	1.3	V	
Rx_LOS Output Voltage - Low	$V_{OL}$	0	0.8	V	
Rx_LOS Output Voltage - High	$V_{OH}$	2.0	$V_{CC}$	V	
MOD_DEF (1) , MOD_DEF (2) - Low	$V_{IL}$	-0.6	$V_{CC} \times 0.3$	V	
MOD_DEF (1) , MOD_DEF (2) - High	$V_{IH}$	$V_{CC} \times 0.7$	$V_{CC} + 0.5$	V	

## TRANSMITTER ELECTRO-OPTICAL CHARACTERISTICS

PARAMETER	SYMBOL	MIN	TYP.	MAX	UNIT	NOTE
Optical Output Power	$P_o$	-3		2	dBm	1
Extinction Ratio	ER	10			dB	
Center Wavelength	$\lambda_c$	1510	1550	1580	nm	
Spectral Width (-20dB)	$\Delta \lambda$			1	nm	
Side Mode Suppression Ratio	SMSR	30			dB	
Optical Rise time (20%-80%)	$t_r$			1.2	ns	2
Optical Fall time (20%-80%)	$t_f$			1.2	ns	2
Output Eye						Compliant with ITU recommendation G.957

# 622Mbps ATM-Single Mode Transceiver



## RECEIVER ELECTRO-OPTICAL CHARACTERISTICS

PARAMETER	SYMBOL	MIN	TYP.	MAX	UNIT	NOTE
Maximum Input Optical Power	$P_{max}$	-3			dBm	3
Receiver Sensitivity	$P_{min}$			-28	dBm	3
Operating Wavelength	$\lambda$	1100		1600	nm	
Loss of Signal - Asserted	$P_A$	-42			dBm	
Loss of Signal - Deasserted	$P_D$			-27	dBm	
Loss of Signal -Hysterisis	$P_D - P_A$	0.5			dB	

### Notes:

1. Measured average power coupled into 9/125  $\mu$ m single mode fiber.
2. These are 20-80% values.
3. Measured with  $2^{23}-1$  PRBS at BER< $10^{-10}$

## TIMING CHARACTERISTICS

PARAMETER	SYMBOL	MIN	TYP.	MAX	UNIT	NOTE
TX_DISABLE Assert Time	$t_{off}$			10	$\mu$ s	
TX_DISABLE Negate Time	$t_{on}$			1	ms	
Time to initialize, include reset of TX_FAULT	$t_{init}$			300	ms	
TX_FAULT from fault to assertion	$t_{fault}$			100	$\mu$ s	
TX_DISABLE time to start reset	$t_{reset}$	10			$\mu$ s	
Receiver Loss of Signal Assert Time (off to on)	$t_{A,RX\_LOS}$			100	$\mu$ s	
Receiver Loss of Signal Assert Time (on to off)	$t_{D,RX\_LOS}$			100	$\mu$ s	

## BLOCK DIAGRAM OF TRANSCEIVER

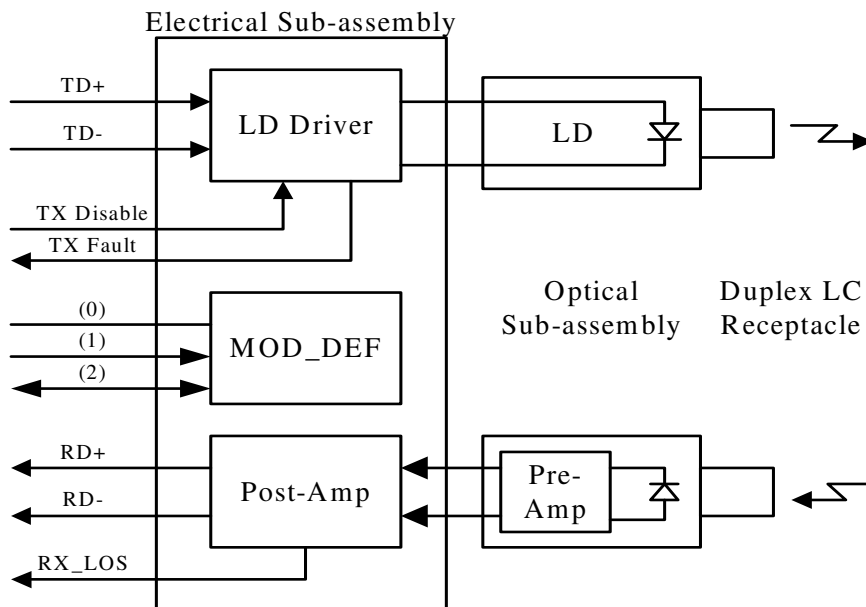

# 622Mbps ATM-Single Mode Transceiver



## PIN OUT DIAGRAM OF TRANSCEIVER

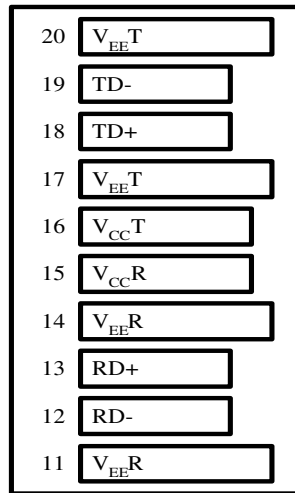

Top of Board

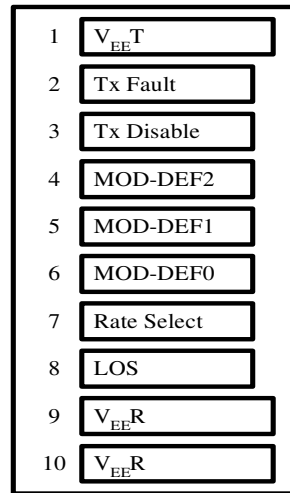

Bottom of Board (As Viewed through Top of Board)

## PIN OUT TABLE

Pin	Symbol	Functional Description
1	V <sub>ee</sub> T	Transmitter Ground
2	TX Fault	Transmitter Fault Indication
3	TX Disable	Transmitter Disable – Module disables on high or open
4	MOD-DEF(2)	Module Definition 2 – Two wire serial ID interface
5	MOD-DEF(1)	Module Definition 1 – Two wire serial ID interface
6	MOD-DEF(0)	Module Definition 0 – Grounded in module
7	Rate Select	Not Connected
8	LOS	Loss of Signal
9	V <sub>ee</sub> R	Receiver Ground
10	V <sub>ee</sub> R	Receiver Ground
11	V <sub>ee</sub> R	Receiver Ground
12	RD-	Inverse Received Data Out
13	RD+	Received Data Out
14	V <sub>ee</sub> R	Receiver Ground
15	V <sub>cc</sub> R	Receiver Power
16	V <sub>cc</sub> T	Transmitter Power
17	V <sub>ee</sub> T	Transmitter Ground
18	TD+	Transmitter Data In
19	TD-	Inverse Transmitter Data In
20	V <sub>ee</sub> T	Transmitter Ground

# 622Mbps ATM-Single Mode Transceiver



## RECOMMENDED CIRCUIT SCHEMATIC

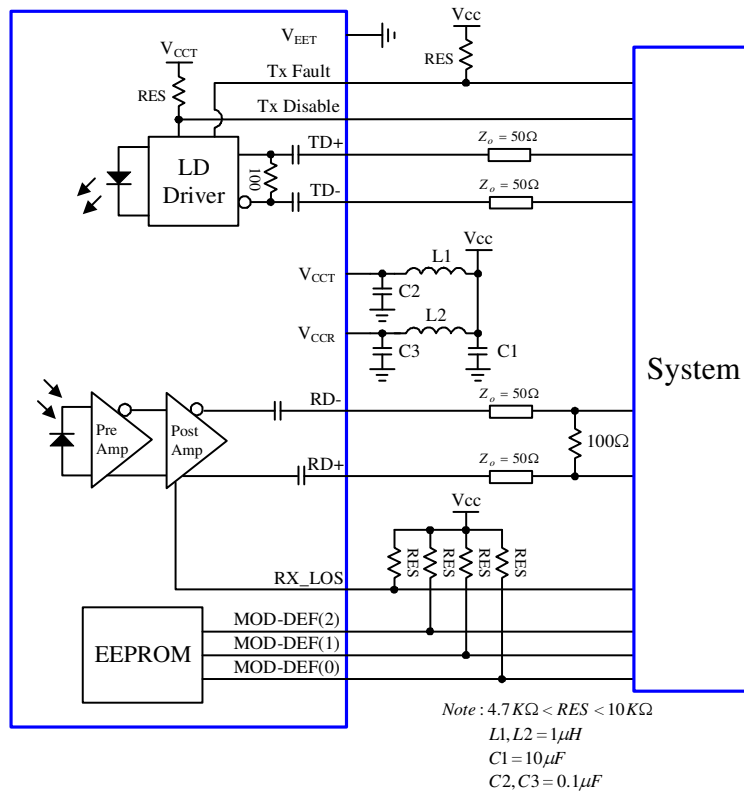

## MECHANICAL DIMENSIONS

Units in mm

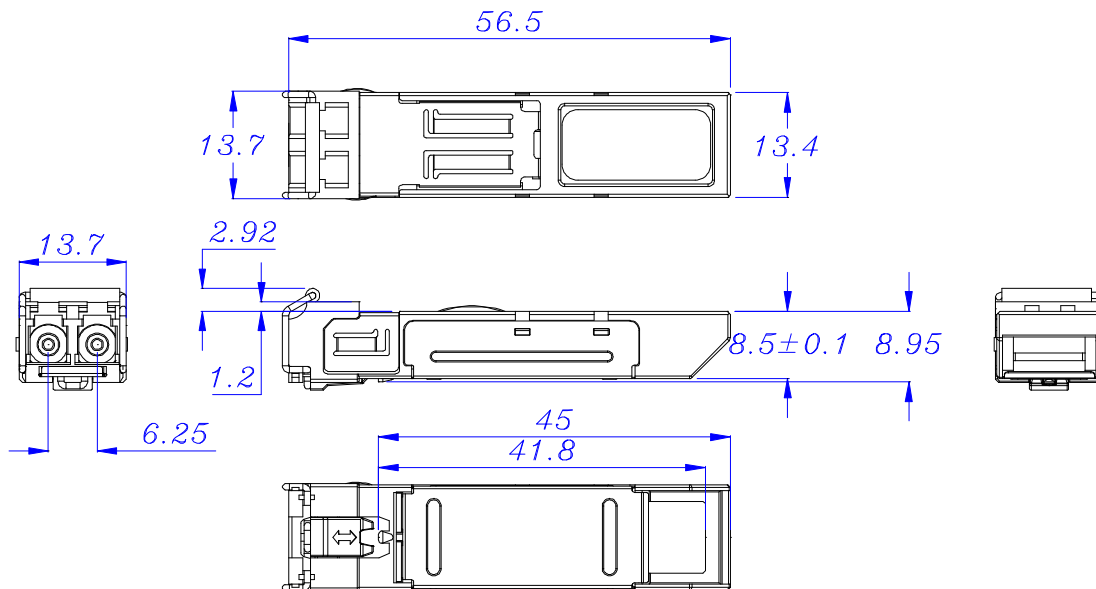

All dimensions are  $\pm 0.2\text{mm}$  unless otherwise specified.

### Claim:

CORETEK Opto Corp. reserves the right to make changes in the specification described hereinafter without prior notice.