

# 155Mbps ATM-Single Mode Transceiver

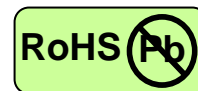

**2×9, Duplex SC/ST Connector, 1310nm FP LD for Single Mode Fiber**

*Extended Operating Temperature from -40 to +85 °C, RoHS Compliant*



## Applications

- Fast Ethernet
- FDDI
- ATM/SONET OC-3/SDH STM-1
- Single mode fiber links
- Optical-Electrical Interface Conversion

## Features

- 1310nm FP LD
- Data Rate: 100Mbps~155Mbps, NRZ
- Single +3.3V Power Supply
- RoHS Compliant and Lead-free
- PECL Differential Electrical Interface/PECL Compatible Logic Interface
- PECL or TTL Signal Detect Output
- Industry Standard 1×9 Output Footprint
- Duplex SC/ST Connector
- Compliance with
  - 100Base-FX of IEEE802.3u Standard
  - FDDI PMD Standard, ATM Standard
- Compliant with SFF-8472 Digital Diagnostic Monitoring Interface
- Eye Safety
  - Designed to meet Laser Class 1 comply with EN60825-1

## Description

The CT-0155TUR-Mx7x-E series from Coretek Opto Corp. are the high performance and cost-effective modules for serial optical data communication applications specified for single mode of 155 Mb/s. It operates with +3.3V power supply. The module is intended for single mode fiber, operates at a nominal wavelength of 1310nm and complies with the industry standard 1x9 footprint with an additional row of pins providing access to TxDisable and integrated digital diagnostics functions via an I<sup>2</sup>C 2-wire serial interface. Each module consists of a transmitter optical subassembly, a receiver optical subassembly and an electrical subassembly. All of them are housed in a plastic package and the combination produces a reliable component.

The module is a dual fiber connector transceiver designed for use in fast Ethernet applications and to provide an ATM/SONET OC-3/SDH STM-1 compliant link for 155 Mb/s long reach applications. The characteristics are performed in accordance with Telcordia Specification GR-468-CORE.

## EMC

Most equipment utilizing high-speed transceivers will be required to meet the following requirements:

- 1) FCC in the United States
- 2) CENELEC EN55022 (CISPR 22) in Europe

To assist the customer in managing the overall equipment EMC performance, the transceivers have been designed to satisfy FCC class B limits and provide good immunity to radio-frequency electromagnetic fields.

## Eye Safety

This laser based single mode transceiver is a Class 1 product. It complies with IEC 60825-1/A2: 2001 and FDA performance standards for laser products (21 CFR 1040.10 and 1040.11) except for deviations pursuant to Laser Notice 50, dated July 26, 2001.

## CLASS 1 LASER PRODUCT

To meet laser safety requirements the transceiver shall be operated within the Absolute Maximum Ratings.

*Note: All adjustments have been made at the factory prior to shipment of the devices. No maintenance or alteration to the device is required. Tampering with or modifying the performance of the device will result in voided product warranty. Failure to adhere to the above restrictions could result in a modification that is considered an act of “manufacturing”, and will require, under law, recertification of the modified product with the U.S. Food and Drug Administration (ref. 21 CFR 1040.10 (i)).*

## Laser Emission Data

<b>Wavelength</b>	<b>: 1310 nm</b>
<b>Maximum total output power</b> <b>(as defined by IEC : 7 mm aperture at 14 mm distance)</b>	<b>: 15.6 mW / 11.9 dBm</b>
<b>Beam divergence (full angle) / NA (half angle)</b>	<b>: 11° / 0.1 rad</b>

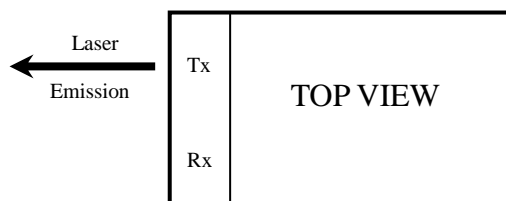

## Required Labels

**IEC :** “Class 1 Laser Product”

**FDA :** “Complies with 21 CFR 1040.10 and 1040.11”

# 155Mbps ATM-Single Mode Transceiver



## Product Information

Model Number	Operating Voltage & SD Output	Connector	Distance	LD Type & Wavelength	Output Power	Sensitivity
CT-0155TUR-M27C-E	3.3V PECL DC/DC	SC	60 km	1310 nm FP	-3 ~ +2 dBm	≤-34 dBm
CT-0155TUR-ME7C-E	3.3V TTL DC/DC					
CT-0155TUR-M27T-E	3.3V PECL DC/DC	ST				
CT-0155TUR-ME7T-E	3.3V TTL DC/DC					

## ABSOLUTE MAX RATINGS

PARAMETER	SYMBOL	MIN	MAX	UNIT	NOTE
Storage Temperature	T <sub>S</sub>	-40	85	°C	
Supply Voltage	V <sub>CC</sub>	0	6	V	
Lead Soldering Temperature/Time	T <sub>SOLD</sub>		260	°C	10 sec on lead
Data Input Voltage	---	0	V <sub>CC</sub>	V	

## OPERATING CONDITIONS

PARAMETER	SYMBOL	MIN.	TYP.	MAX.	UNIT	NOTE
Ambient Operating Temperature	T <sub>A</sub>	-40		85	°C	
Supply Voltage	V <sub>CC</sub>	3.10		3.50	V	

## ELECTRICAL CHARACTERISTICS

PARAMETER	SYMBOL	MIN	MAX	UNIT	NOTE
<b>Transmitter</b>					
Transmitter Supply Current	I <sub>CCR</sub>		200	mA	
Transmitter Data Input Current – Low	I <sub>IL</sub>	-350		μA	
Transmitter Data Input Current – High	I <sub>IH</sub>		350	μA	
Transmitter Data Input Voltage – Low	V <sub>IL</sub> -V <sub>CC</sub>	-1.810	-1.620	V	1
Transmitter Data Input Voltage – High	V <sub>IH</sub> -V <sub>CC</sub>	-1.025	-0.880	V	1
Tx_Disable Input Voltage - Low	V <sub>IL</sub>	0	0.8	V	
Tx_Disable Input Voltage - High	V <sub>IH</sub>	2.0	V <sub>CC</sub>	V	
<b>Receiver</b>					
Receiver Supply Current	I <sub>CCR</sub>		100	mA	
Receiver Data Output Voltage – Low	V <sub>OL</sub> -V <sub>CC</sub>	-1.810	-1.620	V	2
Receiver Data Output Voltage – High	V <sub>OH</sub> -V <sub>CC</sub>	-1.025	-0.880	V	2
Signal Detect Output Voltage – Low (for PECL)	V <sub>OL</sub> -V <sub>CC</sub>	-1.810	-1.620	V	2
Signal Detect Output Voltage – High (for PECL)	V <sub>OH</sub> -V <sub>CC</sub>	-1.025	-0.880	V	2
Signal Detect Output Voltage – Low (for TTL)	V <sub>OL</sub>		0.4	V	2
Signal Detect Output Voltage – High (for TTL)	V <sub>OH</sub>	2.4		V	2

# 155Mbps ATM-Single Mode Transceiver



## TRANSMITTER ELECTRO-OPTICAL CHARACTERISTICS

PARAMETER	SYMBOL	MIN	TYP.	MAX	UNIT	NOTE
Optical Output Power (avg.)	$P_o$	-3		+2	dBm	3
Extinction Ratio	ER	10			dB	4, 5
Center Wavelength	$\lambda_c$	1263	1310	1360	nm	
Spectral Width (RMS)	$\Delta \lambda$			3	nm	
Optical Rise time (10%-90% )	$t_r$			2.0	ns p-p	4
Optical Fall time (10%-90% )	$t_f$			2.0	ns p-p	4
Output Eye	Compliant with Bellcore TR-NWT-000253 and ITU recommendation G.957					

## RECEIVER ELECTRO-OPTICAL CHARACTERISTICS

PARAMETER	SYMBOL	MIN	TYP.	MAX	UNIT	NOTE
Maximum Input Optical Power	$P_{max}$	-3			dBm	5
Receiver Sensitivity	$P_{min}$			-34	dBm	5
Operating Wavelength	$\lambda$	1100		1600	nm	
Signal Detect - Asserted	$P_A$	$P_D+0.5$		-34	dBm	6
Signal Detect - Deasserted	$P_D$	-47			dBm	7
Signal Detect - Hysteresis	$P_A - P_D$	0.5		4	dB	

### Notes:

1. Compatible with 10K, 10KH, 100K ECL and PECL output signals.
2. These outputs are compatible with 10K, 10KH, 100K ECL and PECL inputs.
3. Measured average power coupled into 9/125  $\mu$  m single mode fiber.
4. The input data pattern is a 12.5MHz square wave pattern.
5. Measured with  $2^{23}-1$  PRBS at BER $<10^{-10}$
6. Measured on transition – low to high
7. Measured on transition – high to low

## BLOCK DIAGRAM OF TRANSCEIVER

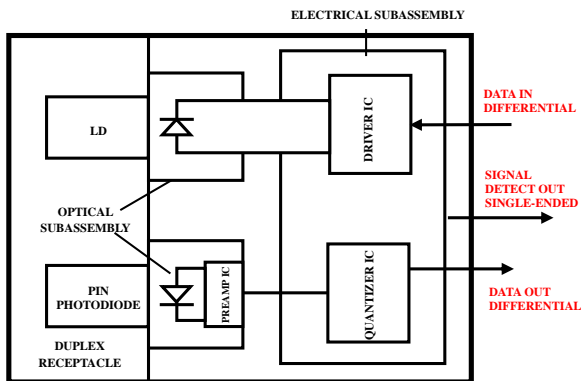

## PIN OUT DIAGRAM OF TRANSCEIVER

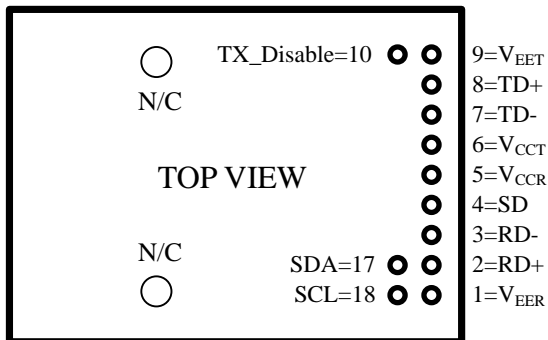

## PIN OUT TABLE

Pin	Symbol	Functional Description
Mounting Posts		
The mounting posts are provided for transceiver mechanical attachment to the circuit board. They should not be connected to the circuit ground but can be connected to the chassis ground.		
1	V <sub>EER</sub>	Receiver Signal Ground
2	RD+	Receiver Data Non-inverted Differential Output
3	RD-	Receiver Data Inverted Differential Output
4	SD	Signal Detect is a PECL or TTL output. A high level indicates a received optical signal
5	V <sub>CCR</sub>	Receiver Power Supply
6	V <sub>CCT</sub>	Transmitter Power Supply
7	TD-	Transmitter Data Inverted Differential Input
8	TD+	Transmitter Data Non-inverted Differential Input
9	V <sub>EET</sub>	Transmitter Signal Ground
10	TX Disable	Transmitter Disable – Module disables on high or open
17	SDA	Two wire serial ID interface - Data
18	SCL	Two wire serial ID interface - Clock

# 155Mbps ATM-Single Mode Transceiver



## RECOMMENDED CIRCUIT SCHEMATIC

### 1) 3.3V SD PECL DC/DC Module

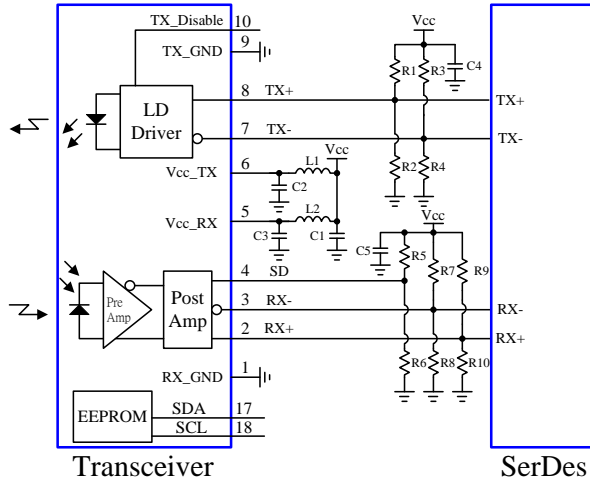

$C1 = 4.7\mu F$      $L1/L2 = 1\mu H$   
 $C2/C3/C4/C5 = 0.1\mu F$   
 $R1/R3/R5/R7/R9 = 130\Omega$   
 $R2/R4/R6/R8/R10 = 82\Omega$

### 2) 3.3V SD TTL DC/DC Module

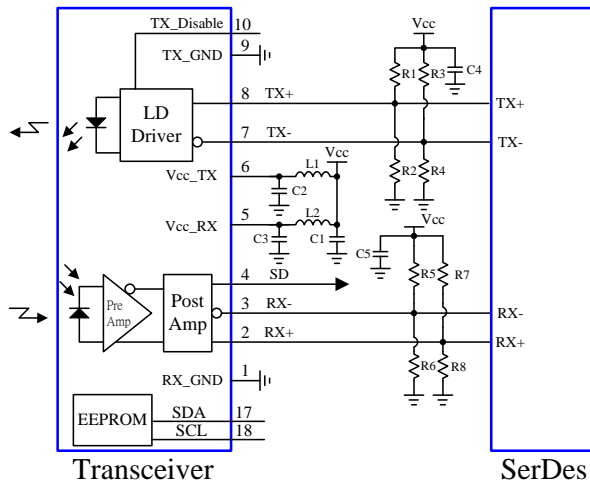

$C1 = 4.7\mu F$      $L1/L2 = 1\mu H$   
 $C2/C3/C4/C5 = 0.1\mu F$   
 $R1/R3/R5/R7/R9 = 130\Omega$   
 $R2/R4/R6/R8/R10 = 82\Omega$

# 155Mbps ATM-Single Mode Transceiver



## MECHANICAL DIMENSIONS

Units in mm

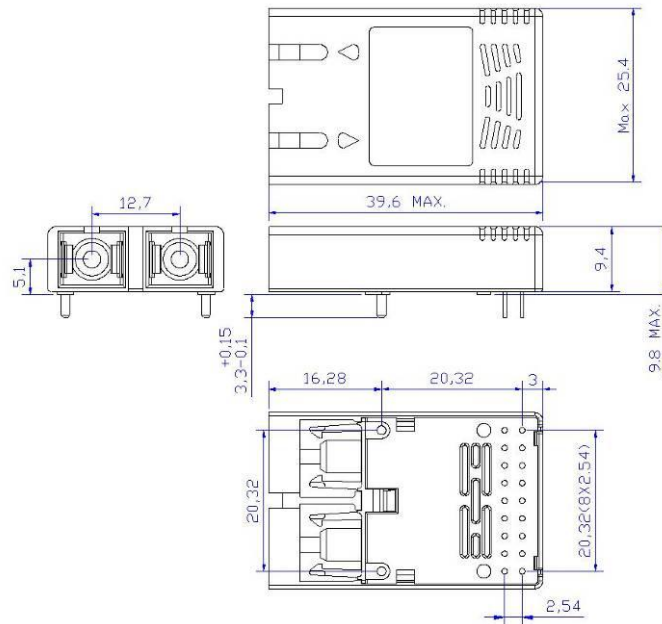

### SC Connector Type

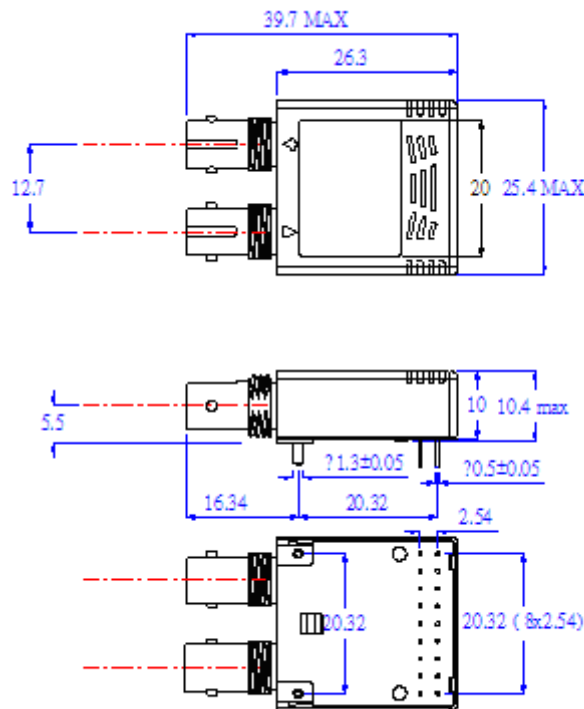

### ST Connector Type

#### Claim:

CORETEK Opto Corp. reserves the right to make changes in the specification described hereinafter without prior notice.