

# 155Mbps ATM-Single Mode Transceiver

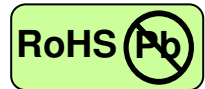

## SFP, Duplex LC Connector, CWDM LD for Single Mode Fiber, RoHS Compliant

Digital Diagnostics Functions, Power Budget 36dB



### Applications

- CWDM
- Fast Ethernet
- FDDI
- ATM/SONET OC-3/SDH STM-1
- Single mode fiber links
- Optical-Electrical Interface Conversion

### Features

- CWDM 8 wavelengths Transmitter
- Data Rate: 155Mbps, NRZ
- Single +3.3V Power Supply
- RoHS Compliant and Lead-free
- AC/AC Differential Electrical Interface
- Compliant with Multi-Source Agreement (MSA) Small Form Factor Pluggable (SFP)
- Compliant with SFF-8472 Digital Diagnostic Monitoring Interface
- Duplex LC Connector
- Compliance with 100Base-FX of IEEE802.3u Standard
- Compliance with FDDI PMD Standard
- Compliance with ATM Standard

### Description

The CT-0155TSP-CBAL series from Coretek Opto Corp. are the high performance and cost-effective modules for serial optical data communication applications specified for single mode of 155 Mb/s. It operates with +3.3V power supply. The module is intended for Single-mode fiber, operates at a nominal wavelength of CWDM and complies with Multi-Source Agreement (MSA) Small Form Factor Pluggable (SFP). Each module is integrated digital diagnostics functions via an I<sup>2</sup>C serial interface.

The module is a duplex LC connector transceiver designed to provide an ATM/SONET OC-3/SDH STM-1 compliant link for 155 Mb/s long reach applications. The characteristics are performed in accordance with ITU-T G.694.2 and G.695.

### EMC

Most equipment utilizing high-speed transceivers will be required to meet the following requirements:

- 1) FCC in the United States
- 2) CENELEC EN55022 (CISPR 22) in Europe

To assist the customer in managing the overall equipment EMC performance, the transceivers have been designed to satisfy FCC class B limits and provide good immunity to radio-frequency electromagnetic fields.

### Eye Safety

The transceivers have been designed to meet Class 1 eye safety and comply with EN 60825-1.

# 155Mbps ATM-Single Mode Transceiver



## Product Information

Model Number	Wavelength	Latch Color	Operating Voltage & SD Output	Distance	Output Power	Sensitivity
CT-0155TSP-CBAL-D	1470 nm	Gray	3.3V TTL AC/AC	120 km	0 ~ +5 dBm	≤ -36 dBm
	1490 nm	Violet				
	1510 nm	Blue				
	1530 nm	Green				
	1550 nm	Yellow				
	1570 nm	Orange				
	1590 nm	Red				
	1610 nm	Brown				

## ABSOLUTE MAX RATINGS

PARAMETER	SYMBOL	MIN	MAX	UNIT	NOTE
Storage Temperature	T <sub>S</sub>	-40	85	°C	
Supply Voltage	V <sub>CC</sub>	0	6	V	
Data Input Voltage	---	0	V <sub>CC</sub>	V	

## OPERATING CONDITIONS

PARAMETER	SYMBOL	MIN.	TYP.	MAX.	UNIT	NOTE
Case Operating Temperature	T <sub>A</sub>	0		70	°C	
Supply Voltage	V <sub>CC</sub>	3.1		3.5	V	
Data Input Voltage Swing	V <sub>ID</sub>	400		1600	mV	

## ELECTRICAL CHARACTERISTICS

PARAMETER	SYMBOL	MIN	MAX	UNIT	NOTE
<b>Transmitter</b>					
Transmitter Supply Current	I <sub>CC1</sub>		200	mA	
Tx_Disable Input Voltage - Low	V <sub>IL</sub>	0	0.8	V	
Tx_Disable Input Voltage - High	V <sub>IH</sub>	2.0	V <sub>CC</sub>	V	
Tx_Fault Output Voltage - Low	V <sub>OL</sub>	0	0.8	V	
Tx_Fault Output Voltage - High	V <sub>OH</sub>	2.0	V <sub>CC</sub>	V	
<b>Receiver</b>					
Receiver Supply Current	I <sub>CC2</sub>		100	mA	
Receiver Data Output Differential Voltage	V <sub>OD</sub>	0.4	1.3	V	
Rx_LOS Output Voltage - Low	V <sub>OL</sub>	0	0.8	V	
Rx_LOS Output Voltage - High	V <sub>OH</sub>	2.0	V <sub>CC</sub>	V	
MOD_DEF (1) , MOD_DEF (2) - Low	V <sub>IL</sub>	-0.6	V <sub>CC</sub> × 0.3	V	
MOD_DEF (1) , MOD_DEF (2) - High	V <sub>IH</sub>	V <sub>CC</sub> × 0.7	V <sub>CC</sub> + 0.5	V	

# 155Mbps ATM-Single Mode Transceiver



## TRANSMITTER ELECTRO-OPTICAL CHARACTERISTICS

PARAMETER	SYMBOL	MIN	TYP.	MAX	UNIT	NOTE
Optical Output Power	P <sub>o</sub>	0		5	dBm	1
Extinction Ratio	ER	10			dB	
Center Wavelength	$\lambda_c$	1464.5	1470	1477.5	nm	
		1484.5	1490	1497.5		
		1504.5	1510	1517.5		
		1524.5	1530	1537.5		
		1544.5	1550	1557.5		
		1564.5	1570	1577.5		
		1584.5	1590	1597.5		
		1604.5	1610	1617.5		
Spectral Width (-20dB)	$\Delta \lambda$			1	nm	
Side Mode Suppression Ratio	SMSR	30			dB	
Optical Rise time ( 10%-90% )	t <sub>r</sub>			2.0	ns	
Optical Fall time ( 10%-90% )	t <sub>f</sub>			2.0	ns	
Output Eye		Compliant with ITU recommendation G.957				

## RECEIVER ELECTRO-OPTICAL CHARACTERISTICS

PARAMETER	SYMBOL	MIN	TYP.	MAX	UNIT	NOTE
Maximum Input Optical Power	P <sub>max</sub>	-3			dBm	2
Receiver Sensitivity	P <sub>min</sub>			-36	dBm	2
Operating Wavelength	$\lambda$	1260		1620	nm	
Loss of Signal - Asserted	P <sub>A</sub>	-45			dBm	
Loss of Signal - Deasserted	P <sub>D</sub>	P <sub>A</sub> +0.5		-35	dBm	
Loss of Signal - Hysteresis	P <sub>D</sub> - P <sub>A</sub>	0.5		4	dB	

### Notes:

1. Measured average power coupled into 9/125  $\mu$  m single mode fiber.
2. Measured with 2<sup>23</sup>-1 PRBS at BER<10<sup>-10</sup>

## TIMING CHARACTERISTICS

PARAMETER	SYMBOL	MIN	TYP.	MAX	UNIT	NOTE
TX_DISABLE Assert Time	t <sub>off</sub>			10	$\mu$ s	
TX_DISABLE Negate Time	t <sub>on</sub>			1	ms	
Time to initialize, include reset of TX_FAULT	t <sub>init</sub>			300	ms	
TX_FAULT from fault to assertion	t <sub>fault</sub>			100	$\mu$ s	
TX_DISABLE time to start reset	t <sub>reset</sub>	10			$\mu$ s	
Receiver Loss of Signal Assert Time (off to on)	t <sub>A,RX_LOS</sub>			100	$\mu$ s	
Receiver Loss of Signal Assert Time (on to off)	t <sub>D,RX_LOS</sub>			100	$\mu$ s	

# 155Mbps ATM-Single Mode Transceiver



## BLOCK DIAGRAM OF TRANSCEIVER

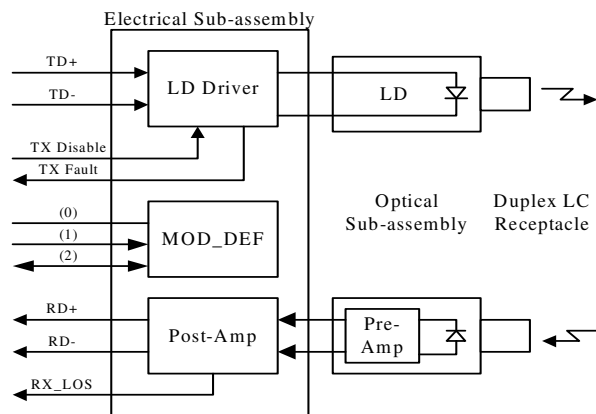

## PIN OUT DIAGRAM OF TRANSCEIVER

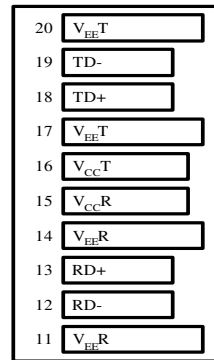

Top of Board

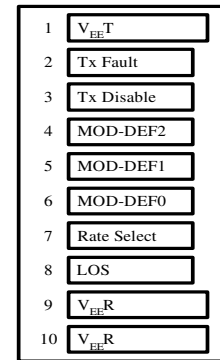

Bottom of Board (As Viewed through Top of Board)

## PIN OUT TABLE

Pin	Symbol	Functional Description
1	VeeT	Transmitter Ground
2	TX Fault	Transmitter Fault Indication
3	TX Disable	Transmitter Disable – Module disables on high or open
4	MOD-DEF(2)	Module Definition 2 – Two wire serial ID interface
5	MOD-DEF(1)	Module Definition 1 – Two wire serial ID interface
6	MOD-DEF(0)	Module Definition 0 – Grounded in module
7	Rate Select	Not Connected
8	LOS	Loss of Signal
9	VeeR	Receiver Ground
10	VeeR	Receiver Ground
11	VeeR	Receiver Ground
12	RD-	Inverse Received Data Out
13	RD+	Received Data Out
14	VeeR	Receiver Ground
15	VccR	Receiver Power
16	VccT	Transmitter Power
17	VeeT	Transmitter Ground
18	TD+	Transmitter Data In
19	TD-	Inverse Transmitter Data In
20	VeeT	Transmitter Ground

# 155Mbps ATM-Single Mode Transceiver



## RECOMMENDED CIRCUIT SCHEMATIC

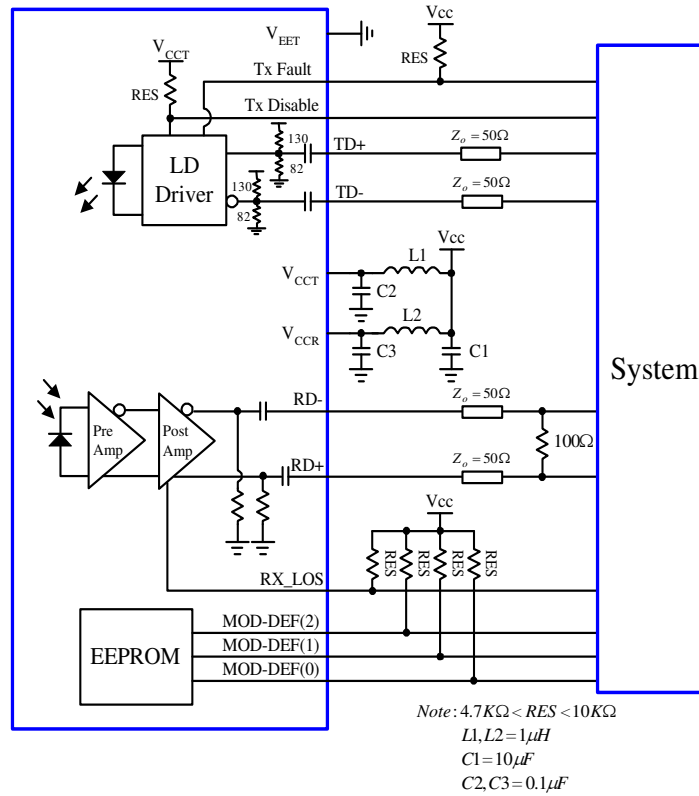

## MECHANICAL DIMENSIONS

Units in mm

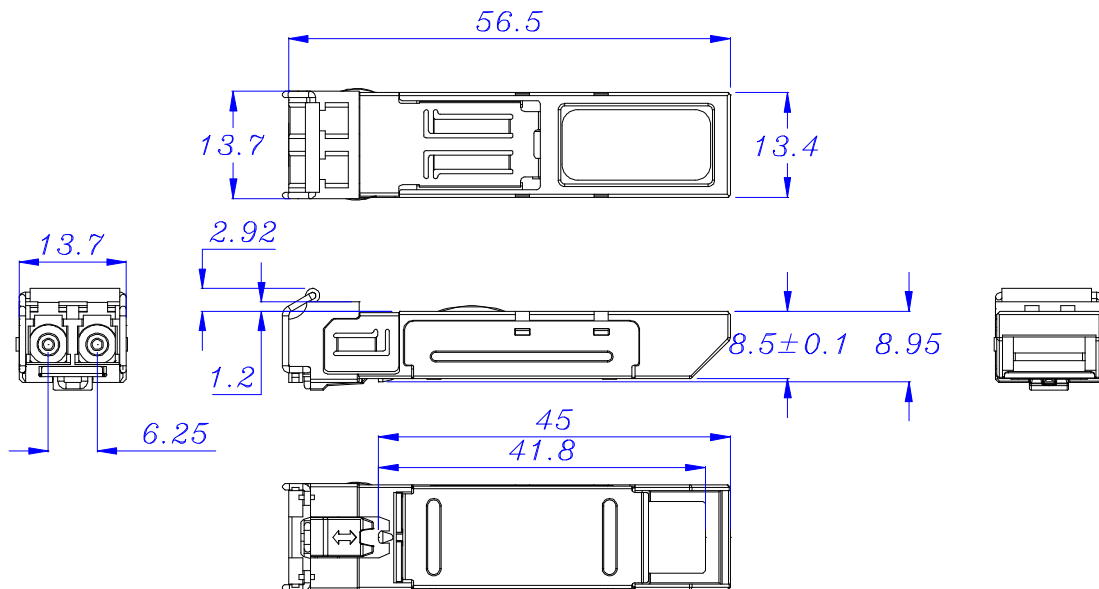

All dimensions are  $\pm 0.2\text{mm}$  unless otherwise specified.

### Claim:

CORETEK Opto Corp. reserves the right to make changes in the specification described hereinafter without prior notice.