

100BASE-BX-ONU Transceiver

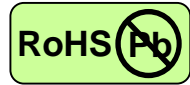

SFP BIDI, Single LC Connector, 1310nm FP LD for Single Mode Fiber, RoHS Compliant
Digital Diagnostics Functions, Extended Operating Temperature from -40 to +85°C



Features

- 1310nm FP LD
- Data Rate: 125~155Mbps, NRZ
- Single +3.3V Power Supply
- RoHS Compliant and Lead-free
- AC/AC Differential Electrical Interface
- Compliant with Multi-Source Agreement (MSA) Small Form Factor Pluggable (SFP)
- Compliant with SFF-8472 Digital Diagnostic Monitoring Interface
- Single LC Connector
- Compliance with specifications for IEEE-802.3ah 100BASE-BX10-U
- Compliance with FDDI PMD Standard
- Compliance with ATM Standard

Applications

- Fast Ethernet
- FDDI
- ATM/SONET OC-3/SDH STM-1
- Single mode fiber links
- Optical-Electrical Interface Conversion

Description

The CT-0155TBP-MB6L-E from Coretek Opto Corp. is the high performance and cost-effective module for serial optical data communication applications specified for single mode of 125 Mb/s. It operates with +3.3V power supply. The module is intended for Single-mode fiber, operates at a nominal wavelength of Tx: 1310nm / Rx: 1550nm and complies with Multi-Source Agreement (MSA) Small Form Factor Pluggable (SFP). Each module is integrated digital diagnostics functions via an I²C serial interface.

The module is a single fiber connector transceiver designed for use in Ethernet applications and to provide IEEE-802.3ah compliant link for 125Mb/s long reach applications. The characteristics are performed in accordance with Telcordia Specification GR-468-CORE.

EMC

Most equipment utilizing high-speed transceivers will be required to meet the following requirements:

- 1) FCC in the United States
- 2) CENELEC EN55022 (CISPR 22) in Europe

To assist the customer in managing the overall equipment EMC performance, the transceivers have been designed to satisfy FCC class B limits and provide good immunity to radio-frequency electromagnetic fields.

Eye Safety

The transceivers have been designed to meet Class 1 eye safety and comply with EN 60825-1.

100BASE-BX-ONU Transceiver



Product Information

Model Number	Operating Voltage & SD Output	Distance	LD Type & Wavelength	Output Power	Sensitivity
CT-0155TBP-MB6L-E	3.3V TTL AC/AC	40 km	1310 nm FP / 1550 nm	-8 ~ -3 dBm	≤ -34 dBm

ABSOLUTE MAX RATINGS

PARAMETER	SYMBOL	MIN	MAX	UNIT	NOTE
Storage Temperature	T _S	-40	85	°C	
Supply Voltage	V _{CC}	0	6	V	
Data Input Voltage	---	0	V _{CC}	V	

OPERATING CONDITIONS

PARAMETER	SYMBOL	MIN.	TYP.	MAX.	UNIT	NOTE
Case Operating Temperature	T _A	-40		85	°C	
Supply Voltage	V _{CC}	3.1		3.5	V	
Data Input Voltage Swing	V _{ID}	400		1600	mV	

ELECTRICAL CHARACTERISTICS

PARAMETER	SYMBOL	MIN	MAX	UNIT	NOTE
Transmitter					
Transmitter Supply Current	I _{CC} T		200	mA	
Tx_Disable Input Voltage - Low	V _{IL}	0	0.8	V	
Tx_Disable Input Voltage - High	V _{IH}	2.0	V _{CC}	V	
Tx_Fault Output Voltage - Low	V _{OL}	0	0.8	V	
Tx_Fault Output Voltage - High	V _{OH}	2.0	V _{CC}	V	
Receiver					
Receiver Supply Current	I _{CC} R		100	mA	
Receiver Data Output Differential Voltage	V _{OD}	0.4	1.3	V	
Rx_LOS Output Voltage - Low	V _{OL}	0	0.8	V	
Rx_LOS Output Voltage - High	V _{OH}	2.0	V _{CC}	V	
MOD_DEF (1) , MOD_DEF (2) - Low	V _{IL}	-0.6	V _{CC} × 0.3	V	
MOD_DEF (1) , MOD_DEF (2) - High	V _{IH}	V _{CC} × 0.7	V _{CC} + 0.5	V	

TRANSMITTER ELECTRO-OPTICAL CHARACTERISTICS

PARAMETER	SYMBOL	MIN	TYP.	MAX	UNIT	NOTE
Optical Output Power	P _o	-8		-3	dBm	1
Extinction Ratio	ER	10			dB	
Center Wavelength	λ _c	1270	1310	1350	nm	
Spectral Width (RMS)	Δ λ			3	nm	
Optical Rise time (10%-90%)	t _r			2.0	ns	
Optical Fall time (10%-90%)	t _f			2.0	ns	
Output Eye	Compliant with IEEE802.3ah and ITU recommendation G.957					

100BASE-BX-ONU Transceiver



RECEIVER ELECTRO-OPTICAL CHARACTERISTICS

PARAMETER	SYMBOL	MIN	TYP.	MAX	UNIT	NOTE
Maximum Input Optical Power	P_{max}	-3			dBm	2
Receiver Sensitivity	P_{min}			-34	dBm	2
Operating Wavelength	λ	1480		1600	nm	
Optical Return Loss	ORL	14			dB	
Loss of Signal - Asserted	P_A	-45			dBm	
Loss of Signal - Deasserted	P_D	$P_A + 0.5$		-33	dBm	
Loss of Signal - Hysteresis	$P_D - P_A$	0.5		4	dB	

Notes:

1. Measured average power coupled into 9/125 μ m single mode fiber.
2. Measured with $2^{23}-1$ PRBS at BER < 10^{-10} and 155Mbps.

TIMING CHARACTERISTICS

PARAMETER	SYMBOL	MIN	TYP.	MAX	UNIT	NOTE
TX_DISABLE Assert Time	t_{off}			10	μ s	
TX_DISABLE Negate Time	t_{on}			1	ms	
Time to initialize, include reset of TX_FAULT	t_{init}			300	ms	
TX_FAULT from fault to assertion	t_{fault}			100	μ s	
TX_DISABLE time to start reset	t_{reset}	10			μ s	
Receiver Loss of Signal Assert Time (off to on)	t_{A,RX_LOS}			100	μ s	
Receiver Loss of Signal Assert Time (on to off)	t_{D,RX_LOS}			100	μ s	

BLOCK DIAGRAM OF TRANSCEIVER

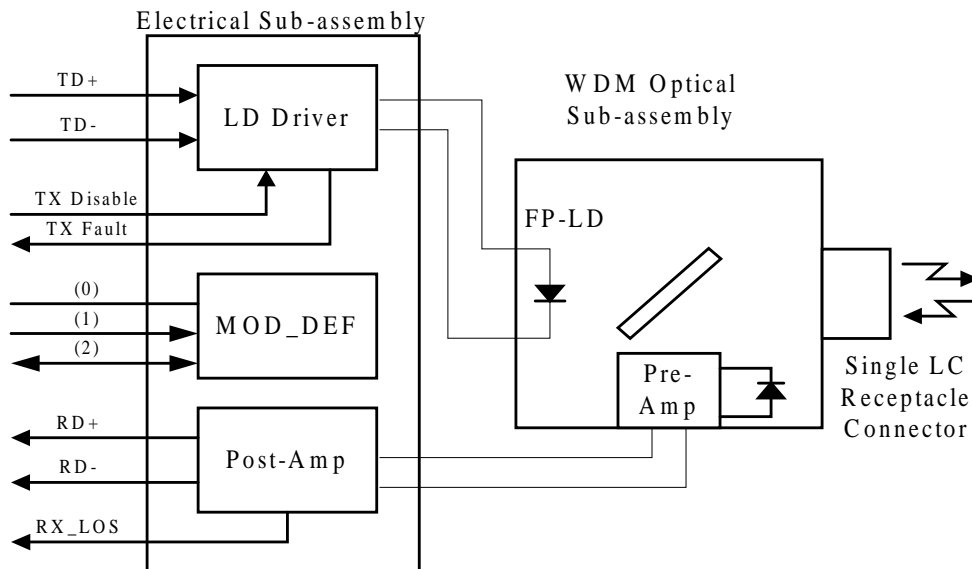

PIN OUT DIAGRAM OF TRANSCEIVER

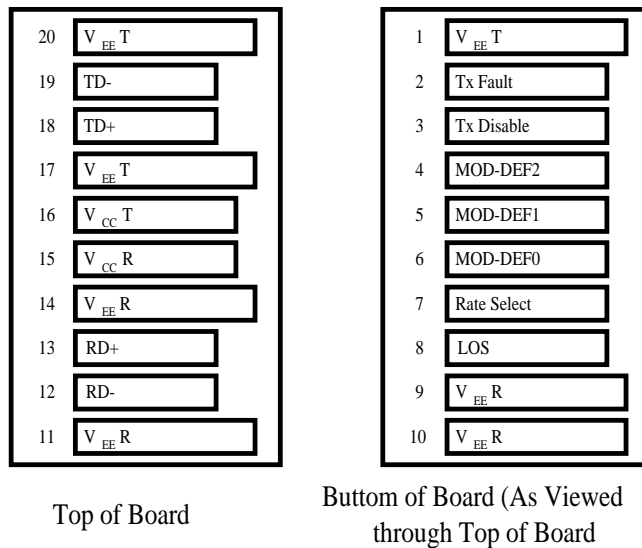

PIN OUT TABLE

Pin	Symbol	Functional Description
1	VeeT	Transmitter Ground
2	TX Fault	Transmitter Fault Indication
3	TX Disable	Transmitter Disable – Module disables on high or open
4	MOD-DEF(2)	Module Definition 2 – Two wire serial ID interface
5	MOD-DEF(1)	Module Definition 1 – Two wire serial ID interface
6	MOD-DEF(0)	Module Definition 0 – Grounded in module
7	Rate Select	Not Connected
8	LOS	Loss of Signal
9	VeeR	Receiver Ground
10	VeeR	Receiver Ground
11	VeeR	Receiver Ground
12	RD-	Inverse Received Data Out
13	RD+	Received Data Out
14	VeeR	Receiver Ground
15	VccR	Receiver Power
16	VccT	Transmitter Power
17	VeeT	Transmitter Ground
18	TD+	Transmitter Data In
19	TD-	Inverse Transmitter Data In
20	VeeT	Transmitter Ground

RECOMMENDED CIRCUIT SCHEMATIC

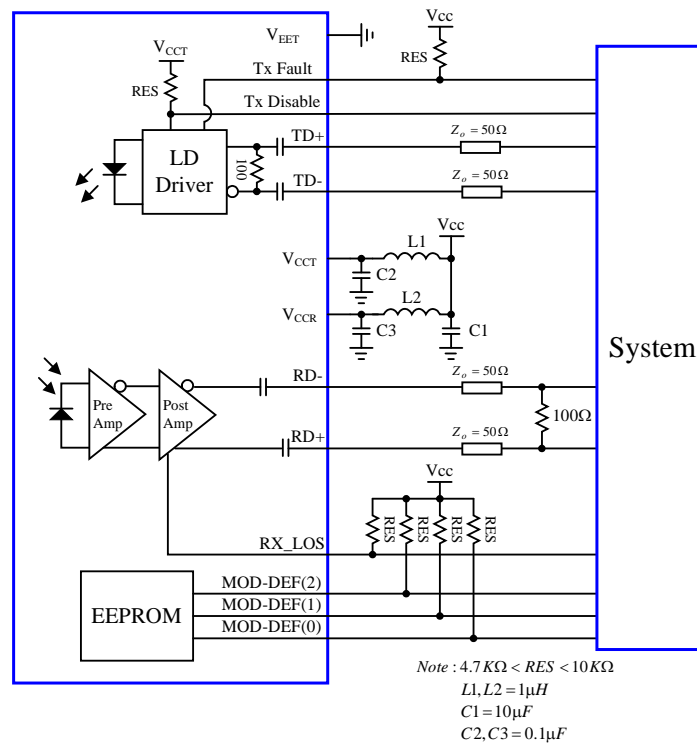

MECHANICAL DIMENSIONS

Units in mm

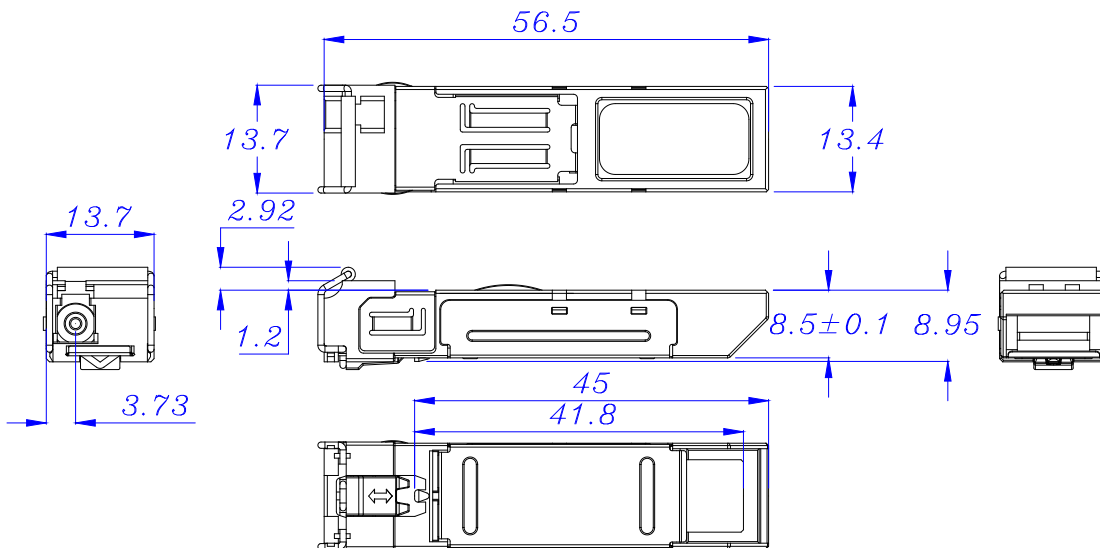

All dimensions are $\pm 0.2\text{mm}$ unless otherwise specified.

Claim:

CORETEK Opto Corp. reserves the right to make changes in the specification described hereinafter without prior notice.