

155Mbps ATM-Multimode Transceiver

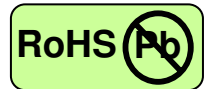

2x5 SFF, Duplex LC Connector, 1310nm LED for Multimode Fiber, RoHS Compliant

Extended Operating Temperature from -40 to +85 °C



Features

- 1310nm LED
- Data Rate: 100~155Mbps, NRZ
- Single +3.3V Power Supply
- RoHS Compliant and Lead-free
- PECL Differential Electrical Interface
- Compliant with Multi-Source Agreement (MSA) Small Form Factor (SFF) 2x5 Footprint
- Duplex LC Connector
- Compliance with
 - 100Base-FX of IEEE802.3u Standard
 - FDDI PMD Standard
 - ATM Standard
- Eye Safety
 - Designed to meet Laser Class 1 comply with EN60825-1

Applications

- Fast Ethernet
- FDDI
- ATM/SONET OC-3/SDH STM-1
- Multimode fiber links
- Optical-Electrical Interface Conversion

Description

The CT-0155NSR-Mx2L-A series from Coretek Opto Corp. are the high performance and cost-effective modules for serial optical data communication applications specified for multimode of 155 Mb/s. It operates with +3.3V power supply. The module is intended for multimode fiber, operates at a nominal wavelength of 1310nm and complies with Multi-Source Agreement (MSA) Small Form Factor (SFF) 2x5 footprint. Each module consists of a transmitter optical subassembly, a receiver optical subassembly and an electrical subassembly. All of them are housed in a plastic package and the combination produces a reliable component.

The module is a duplex LC transceiver designed for use in fast Ethernet applications and to provide an ATM/SONET OC-3/SDH STM-1 compliant link for 155 Mb/s short reach applications. The characteristics are performed in accordance with Telcordia Specification GR-468-CORE.

EMC

Most equipment utilizing high-speed transceivers will be required to meet the following requirements:

- 1) FCC in the United States
- 2) CENELEC EN55022 (CISPR 22) in Europe

To assist the customer in managing the overall equipment EMC performance, the transceivers have been designed to satisfy FCC class B limits and provide good immunity to radio-frequency electromagnetic fields.

Eye Safety

The transceivers have been designed to meet Class 1 eye safety and comply with EN 60825-1.

155Mbps ATM-Multimode Transceiver



Product Information:

Model Number	Operating Voltage & SD Output	Distance	Wavelength	Output Power	Sensitivity
CT-0155NSR-M22L-A	3.3V PECL DC/DC	2 km	1310 nm	-19 ~ -14 dBm	≤ -32 dBm
CT-0155NSR-ME2L-A	3.3V TTL DC/DC				

ABSOLUTE MAX RATINGS

PARAMETER	SYMBOL	MIN	MAX	UNIT	NOTE
Storage Temperature	T_S	-40	85	$^{\circ}\text{C}$	
Supply Voltage	V_{CC}	0	6	V	
Lead Soldering Temperature/Time	T_{SOLD}		260	$^{\circ}\text{C}$	10 sec on lead
Data Input Voltage	---	0	V_{CC}	V	

OPERATING CONDITIONS

PARAMETER	SYMBOL	MIN.	TYP.	MAX.	UNIT	NOTE
Ambient Operating Temperature	T_A	-40		85	$^{\circ}\text{C}$	
Supply Voltage	V_{CC}	3.1		3.5	V	

ELECTRICAL CHARACTERISTICS

PARAMETER	SYMBOL	MIN	MAX	UNIT	NOTE
Transmitter					
Transmitter Supply Current	I_{CCT}		140	mA	
TTL Transmit Disable Input Voltage - Low	V_{IL}		0.8	V	
TTL Transmit Disable Input Voltage - High	V_{IH}	$V_{CC}-1.3$	V_{CC}	V	
Receiver					
Receiver Supply Current	I_{CCR}		100	mA	
Receiver Data Output Voltage - Low	$V_{OL}-V_{CC}$	-1.810	-1.620	V	1
Receiver Data Output Voltage - High	$V_{OH}-V_{CC}$	-1.025	-0.880	V	1
Signal Detect Output Voltage - Low (for PECL)	$V_{OL}-V_{CC}$	-1.810	-1.620	V	1
Signal Detect Output Voltage - High (for PECL)	$V_{OH}-V_{CC}$	-1.025	-0.880	V	1
Signal Detect Output Voltage - Low (for TTL)	$V_{OL}-V_{CC}$		0.4	V	1
Signal Detect Output Voltage - High (for TTL)	$V_{OH}-V_{CC}$	2.4		V	1

TRANSMITTER ELECTRO-OPTICAL CHARACTERISTICS

PARAMETER	SYMBOL	MIN	TYP.	MAX	UNIT	NOTE
Optical Output Power (avg.)	P_o	-19	-17	-14	dBm	2
Extinction Ratio	ER	8.2			dB	
Center Wavelength	λ_c	1270		1360	nm	
Spectral Width (RMS)	$\Delta \lambda$			200	nm	
Optical Rise time (10%-90%)	t_r	0.6		3.0	ns p-p	3
Optical Fall time (10%-90%)	t_f	0.6		3.0	ns p-p	3
Output Eye		Compliant with ITU recommendation G.957				

155Mbps ATM-Multimode Transceiver



RECEIVER ELECTRO-OPTICAL CHARACTERISTICS

PARAMETER	SYMBOL	MIN	TYP.	MAX	UNIT	NOTE
Maximum Input Optical Power	P_{max}	-14			dBm	4
Receiver Sensitivity	P_{min}			-32	dBm	4
Operating Wavelength	λ	1100		1600	nm	
Signal Detect - Asserted	P_A			-32	dBm	5
Signal Detect - Deasserted	P_D	-47			dBm	6
Signal Detect - Hysteresis	$P_A - P_D$	0.5		4	dB	

Notes:

1. These outputs are compatible with 10K, 10KH, 100K ECL and PECL inputs.
2. Measured average power coupled into 62.5/125 μ m, 0.275 NA graded index multimode fiber.
3. These are 10-90% values.
4. Measured with $2^{23}-1$ PRBS at $BER < 10^{-10}$
5. Measured on transition – low to high
6. Measured on transition – high to low

BLOCK DIAGRAM OF TRANSCEIVER

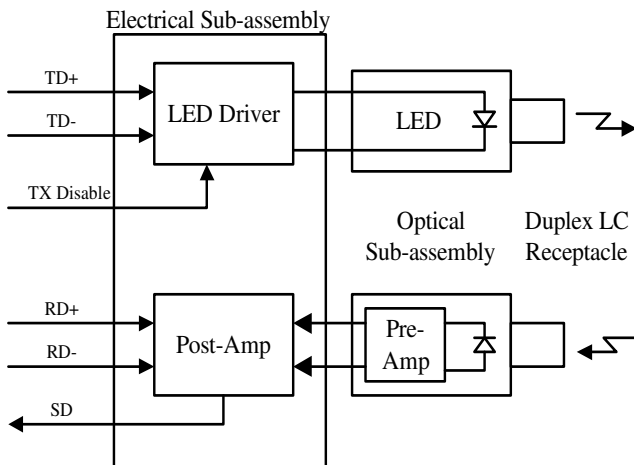

PIN OUT DIAGRAM OF TRANSCEIVER

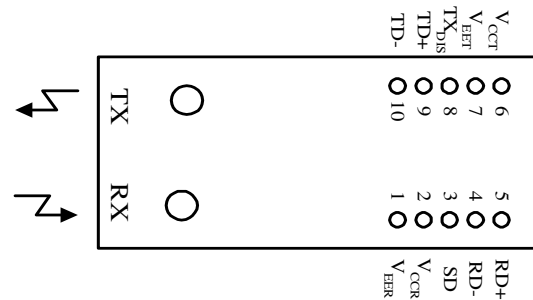

PIN OUT TABLE

Pin	Symbol	Functional Description
Mounting Posts		
The mounting posts are provided for transceiver mechanical attachment to the circuit board. They should not be connected to the circuit ground but can be connected to the chassis ground.		
1	V_{EER}	Receiver Signal Ground
2	V_{CCR}	Receiver Power Supply
3	SD	Signal Detect is a PECL or TTL output. A high level indicates a received optical signal
4	RD-	Receiver Data Inverted Differential Output
5	RD+	Receiver Data Non-inverted Differential Output
6	V_{CCT}	Transmitter Power Supply
7	V_{EET}	Transmitter Signal Ground
8	TX_{DIS}	Transmitter Disable
9	TD+	Transmitter Data Non-inverted Differential Input
10	TD-	Transmitter Data Inverted Differential Input

155Mbps ATM-Multimode Transceiver



RECOMMENDED CIRCUIT SCHEMATIC

1) 3.3V SD PECL Module

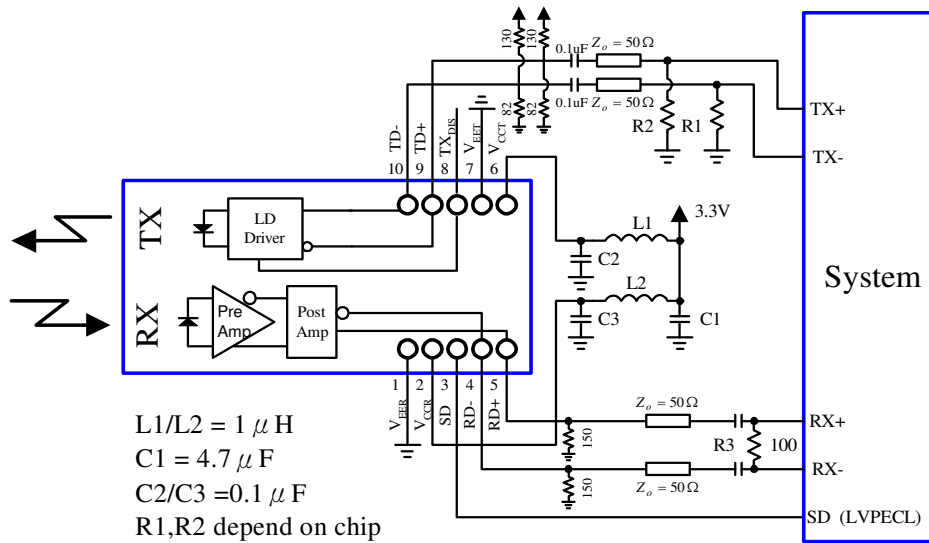

2) 3.3V SD TTL Module

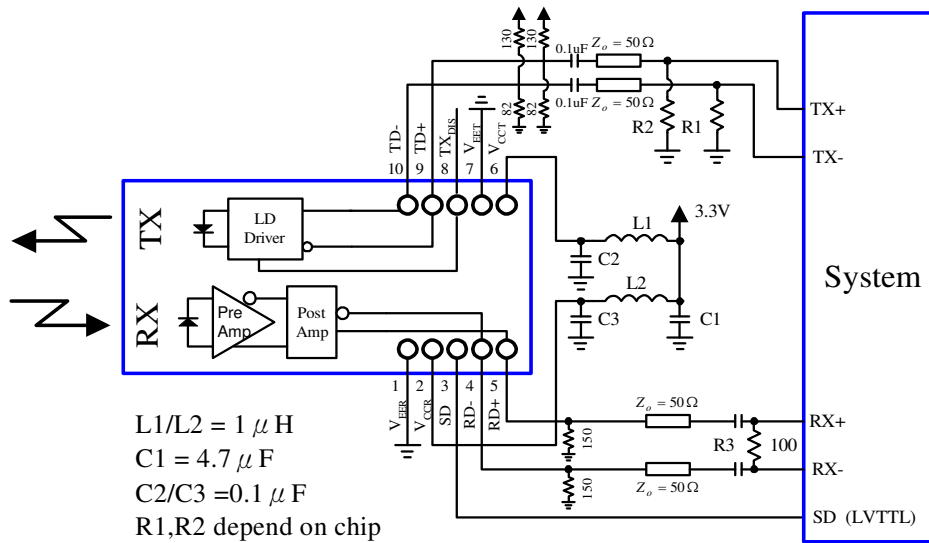

155Mbps ATM-Multimode Transceiver



MECHANICAL DIMENSIONS

Units in mm

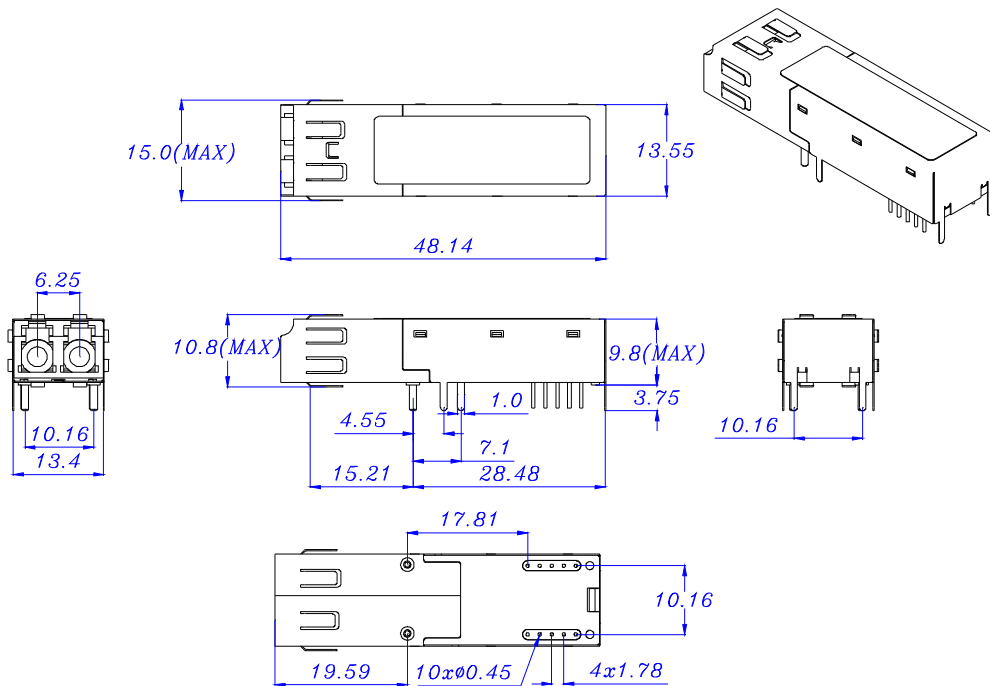

All dimensions are ± 0.2 mm unless otherwise specified.

RECOMMENDED SFF HOST BOARD LAYOUT

Units in mm

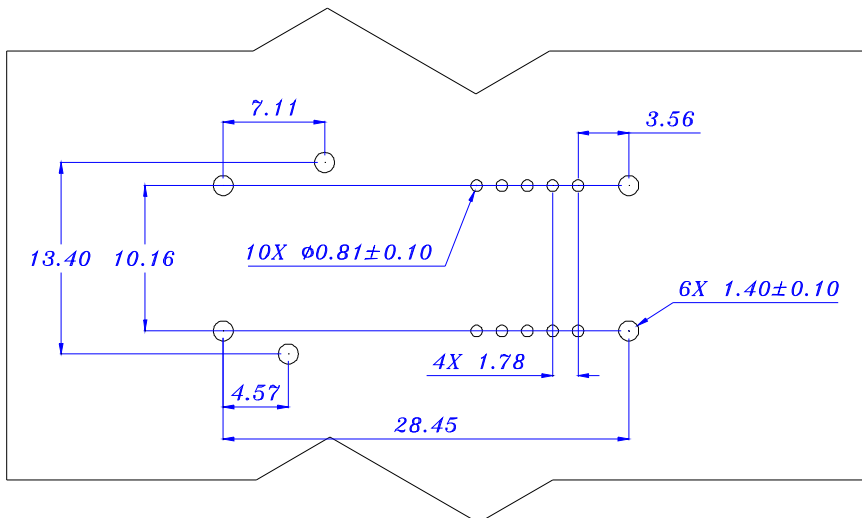

Claim:

CORETEK Opto Corp. reserves the right to make changes in the specification described hereinafter without prior notice.