

DC to 0.5Mb/s - Single Mode Transceiver

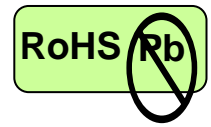

1×9, Duplex SC Connector, 1310 nm FP LD for Single Mode Fiber, RoHS Compliant



Features

- 1310 nm FP LD
- Data Rate: DC~0.5 Mb/s
- Single +5 V Power Supply
- RoHS Compliant and Lead-free
- TTL Electrical Data Interface
- Industry Standard 1×9 Output Footprint
- Duplex SC Connector
- Eye Safety

Designed to meet Laser Class 1 comply with EN60825-1

Applications

- PDH Data Transmission
- Fiber Modem
- Fiber Monitor System
- Single Mode fiber links
- Optical-Electrical Interface Conversion

Description

The CT-000ATTR-M15C from Coretek Opto Corp. is the high performance and cost-effective module for serial optical data communication applications specified for data-rates of 0.5 Mb/s. It operates with a +5 V power supply. The module is intended for single mode fiber, operates at a nominal wavelength of 1310 nm and complies with the industry standard 1x9 footprint. Each module consists of a transmitter optical subassembly, a receiver optical subassembly and an electrical subassembly. All of them are housed in a plastic package and the combination produces a reliable component.

The module is a dual fiber connector transceiver designed for use in PDH (Plesiochronous Digital Hierarchy) data transmission for 0.5 Mb/s long reach application. The characterization is performed in accordance with Telcordia Specification GR-468-CORE.

EMC

Most equipment utilizing high-speed transceivers will be required to meet the following requirements:

- 1) FCC in the United States
- 2) CENELEC EN55022 (CISPR 22) in Europe

To assist the customer in managing the overall equipment EMC performance, the transceivers have been designed to satisfy FCC class B limits and provide good immunity to radio-frequency electromagnetic fields.

Eye Safety

The transceivers have been designed to meet Class 1 eye safety and comply with EN 60825-1.

DC to 0.5Mb/s - Single Mode Transceiver



Product Information

Model Number	Operating Voltage & Data Interface	Connector	Distance	LD Type & Wavelength	Output Power	Sensitivity
CT-000ATTR-M15C	5 V TTL	SC	20 km	1310 nm FP	-13 ~ -8 dBm	\leq -22 dBm

ABSOLUTE MAX RATINGS

PARAMETER	SYMBOL	MIN	MAX	UNIT	NOTE
Storage Temperature	T _S	-40	85	°C	
Supply Voltage	V _{CC}	0	6	V	
Lead Soldering Temperature/Time	T _{SOLD}		260	°C	10 sec on lead
Data Input Voltage	---	0	V _{CC}	V	

OPERATING CONDITIONS

PARAMETER	SYMBOL	MIN.	TYP.	MAX.	UNIT	NOTE
Ambient Operating Temperature	T _A	0		70	°C	
Supply Voltage	V _{CC}	4.75		5.25	V	

ELECTRICAL CHARACTERISTICS

PARAMETER	SYMBOL	MIN	MAX	UNIT	NOTE
Transmitter					
Transmitter Supply Current	I _{CCT}		100	mA	
Transmitter Data Input Voltage – Low	V _{IL}		0.4	V	
Transmitter Data Input Voltage – High	V _{IH}	2.4		V	
Receiver					
Receiver Supply Current	I _{CCR}		100	mA	
Receiver Data Output Voltage – Low	V _{OL}		0.4	V	
Receiver Data Output Voltage – High	V _{OH}	2.4		V	

TRANSMITTER ELECTRO-OPTICAL CHARACTERISTICS

PARAMETER	SYMBOL	MIN	TYP.	MAX	UNIT	NOTE
Optical Output Power	P _o	-13		-8	dBm	1
Extinction Ratio	ER	10			dB	2, 3
Center Wavelength	λ_c	1270	1310	1355	nm	
Spectral Width (RMS)	$\Delta \lambda$			7	nm	

RECEIVER ELECTRO-OPTICAL CHARACTERISTICS

PARAMETER	SYMBOL	MIN	TYP.	MAX	UNIT	NOTE
Maximum Input Optical Power	P _{max}	-3			dBm	
Receiver Sensitivity	P _{min}			-22	dBm	4
Operating Wavelength	λ	1100		1600	nm	

DC to 0.5Mb/s - Single Mode Transceiver



Notes:

1. Measured average power coupled into 9/125 μm single mode fiber.
2. Measured on transition – low to high
3. Measured on transition – high to low
4. Measured with square wave pattern.

BLOCK DIAGRAM OF TRANSCEIVER

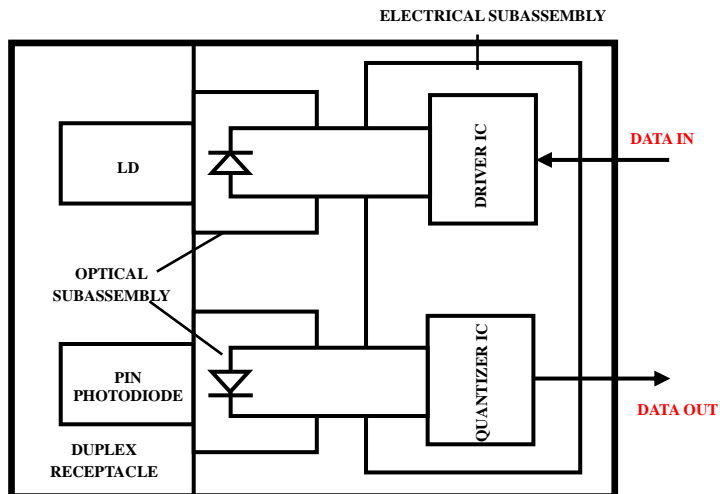

PIN OUT DIAGRAM OF TRANSCEIVER

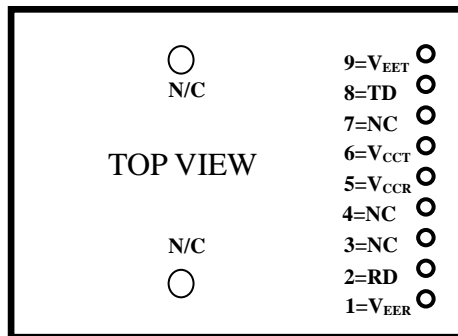

Pin	Symbol	Functional Description
Mounting Posts		
The mounting posts are provided for transceiver mechanical attachment to the circuit board. They should not be connected to the circuit ground but can be connected to the chassis ground.		
1	V _{EER}	Receiver Signal Ground
2	RD	Receiver Data TTL Output
3	NC	NC
4	NC	NC
5	V _{CCR}	Receiver Power Supply
6	V _{CCT}	Transmitter Power Supply
7	NC	NC
8	TD	Transmitter Data TTL Input
9	V _{EET}	Transmitter Signal Ground

DC to 0.5Mb/s - Single Mode Transceiver



RECOMMENDED CIRCUIT SCHEMATIC

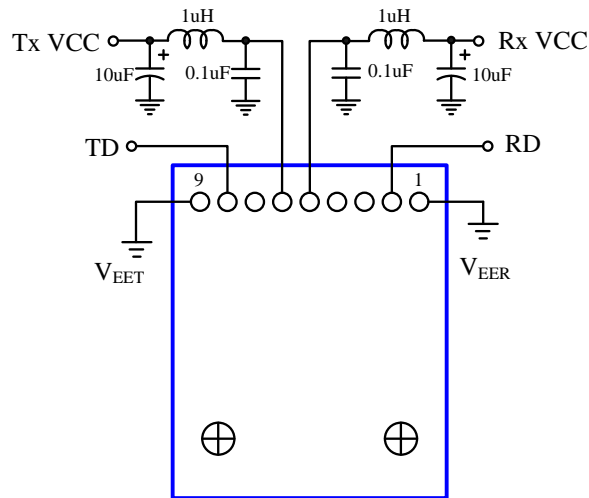

Data (TD,RD) - TTL

MECHANICAL DIMENSIONS

Units in mm

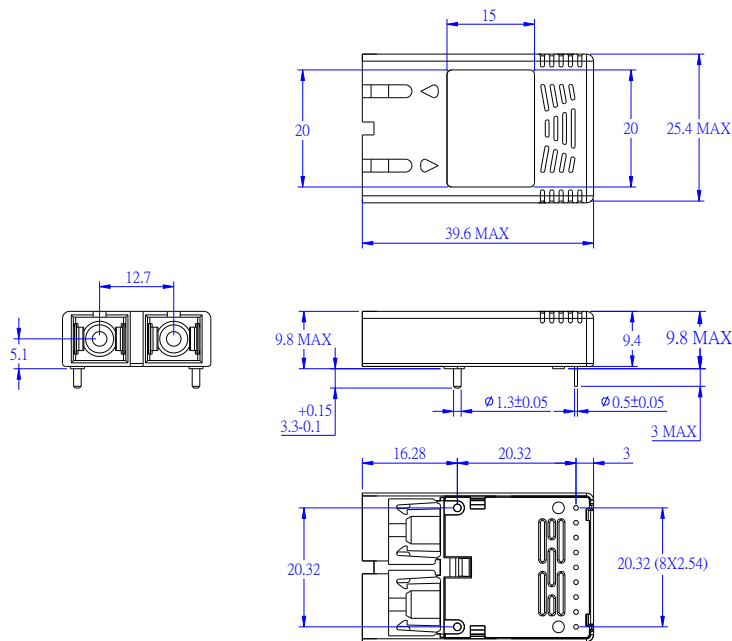

DIMENSIONS ARE IN MILLIMETERS.
ALL DIMENSIONS ARE 0.1mm UNLESS OTHERWISE SPECIFIED.

Claim:

CORETEK Opto Corp. reserves the right to make changes in the specification described hereinafter without prior notice.